



CHUCK

Closed Centre Power Chuck

N series

Closed Centre Standard Chuck

The standard Closed Centre chuck

*CE correspondence



Dimensional Drawings

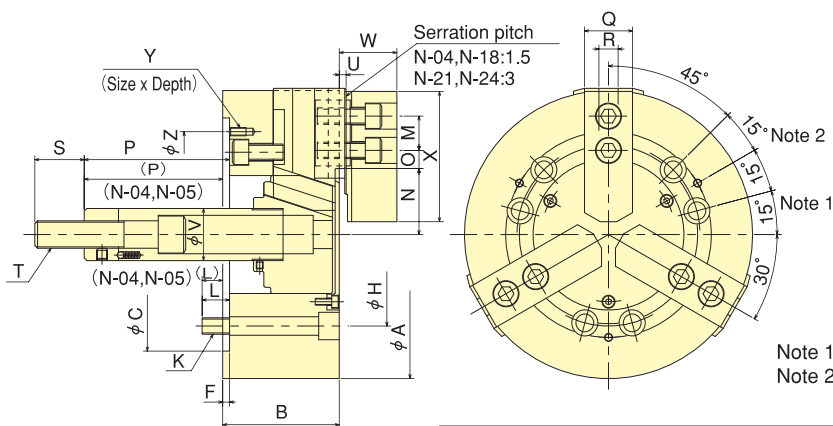

Gripping Characteristic Graphs

※With standard blank soft top jaw.

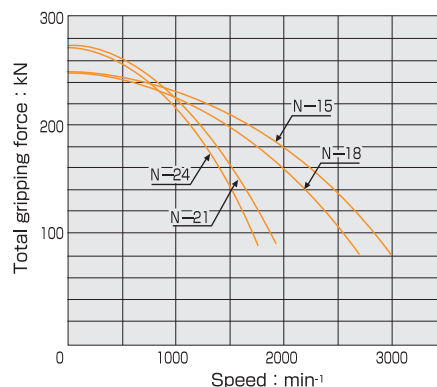
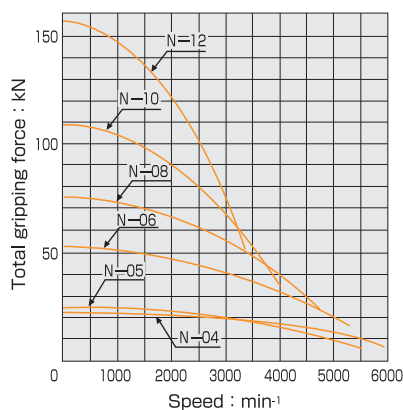

Dimensions

※Mounting bolt P. C. D. for N-04 & N-05 : 120° pitch : 3 pcs. ※Mounting bolt P. C. D. for N-21 & N-24 : 60° pitch : 6 pcs.

Dimensions Model	A	B	C (H6)	F	H	J	K	L	M	N max.	N min.	O max.	O min.	P max.	P min.	Q	R	S	T	U	V	W	X	Y	Z
N-04	110	52	60	6	80	-	3-M8	12	14	23.3	20.1	11.25	8.25	18	3	23	10	25	M10	3	26	27	55	-	-
N-05	135	55	80	7	100	-	3-M8	14	19	30.4	27.2	11.25	6.75	9	-6	23	10	35	M12	3	28	29	62	-	-
N-06	165	74	140	5	104.8	21	6-M10	14	20	37.8	33.55	13.75	7.75	101.5	81.5	31	12	36	M16	4	34	35	72	M6×10	116
N-08	210	85	170	5	133.4	25	6-M12	20	25	46.3	41.9	22.25	11.75	127	106	35	14	36	M20	5	38	42	95	M6×12	150
N-10	254	89	220	5	171.4	34	6-M16	18	30	51.1	46.7	30.75	11.25	158	133	40	16	36	M20	5	45	46	110	M8×15	190
N-12	304	106	220	6	171.4	34	6-M16	18	30	61	55.75	48.75	12.75	163	133	50	18	36	M20	5	50	54	129	M8×15	190
N-15	381	114	300	6	235	-	6-M20	30	43	77.5	69.5	48.75	23.25	104	69	50	25.5	55	M30	2	60	61	135	M10×20	260
N-18	450	114	300	6	235	-	6-M20	30	43	108	100	48.75	23.25	92	57	50	25.5	55	M30	2	60	61	135	M10×20	260
N-21	530	125	380	6	330.2	-	6-M22	31	60	86	78	93.5	27.5	97	62	65	25	55	M30	3	60	71	180	M12×30	330.2
N-24	610	125	380	6	330.2	-	6-M22	31	60	125	117	93.5	27.5	97	62	65	25	55	M30	3	60	71	180	M12×30	330.2

Specifications

※Max. speed is shown using actual test data. ※For large type more than N-24, confer with KITAGAWA.

Specifications Model	Gripping range mm Max.	Gripping range mm Min.	Jaw Stroke (diameter) mm	Plunger Stroke mm	Max. Draw Bar Pull Force kN (kgf)	Max. Gripping Force kN (kgf)	Max. Speed min⁻¹	Net Weight with Soft top jaws kg	Moment of inertia kg·m²	Matching pressure	Cylinder air	Max. pressure MPa(kgf/cm²)	Matching Hard top jaw	Matching Soft top jaw
N-04	110	8	6.4	15	8.2 (836)	22.8 (2325)	6000	4.1	0.008	Y0715R	AY1315R	2.4 (24.5)	-	SB04B1
N-05	135	16	6.4	15	8.2 (836)	25.2 (2570)	5500	6.2	0.015	Y0715R	AY1315R	2.4 (24.5)	HBO5C1	SB05B1
N-06	165	19	8.5	20	18 (1835)	52.5 (5353)	5270	13	0.045	Y1020R	AY1720R	2.6 (26.5)	HBO6B1	SB06B1
N-08	210	23	8.8	21	25 (2549)	75 (7648)	4760	25	0.138	Y1225R	AY2225R	2.5 (25.5)	HBO8A1	SB08B1
N-10	254	24	8.8	25	29 (2957)	108 (11013)	4010	37	0.300	Y1225R	AY2225R	2.8 (28.6)	HB10A1	SB10B1
N-12	304	26	10.5	30	41 (4181)	156 (15907)	3380	57.3	0.725	Y1530R	-	2.7 (27.5)	HB12B1	SB12A1
N-15	381	72	16	35	82 (8362)	249 (25391)	3040	101	1.9	Y2035R	-	3.2 (32.6)	HB15N1	SB15N1
N-18	450	133	16	35	82 (8362)	249 (25391)	2710	126	3.3	Y2035R	-	3.2 (32.6)	HB15N1	SB15N1
N-21	530	62	16	35	82 (8362)	273 (27838)	1940	198	7.1	Y2035R	-	3.2 (32.6)	HB18B2	SB18A2
N-24	610	152	16	35	82 (8362)	273 (27838)	1760	252	12.0	Y2035R	-	3.2 (32.6)	HB18B2	SB18A2



CHUCK

Closed Centre Power Chuck (Direct Mount) N-A series

Chuck Adaptor is equipped to suit Spindle Nose Closed Centre standard chuck

* CE correspondence



Dimensional Drawings

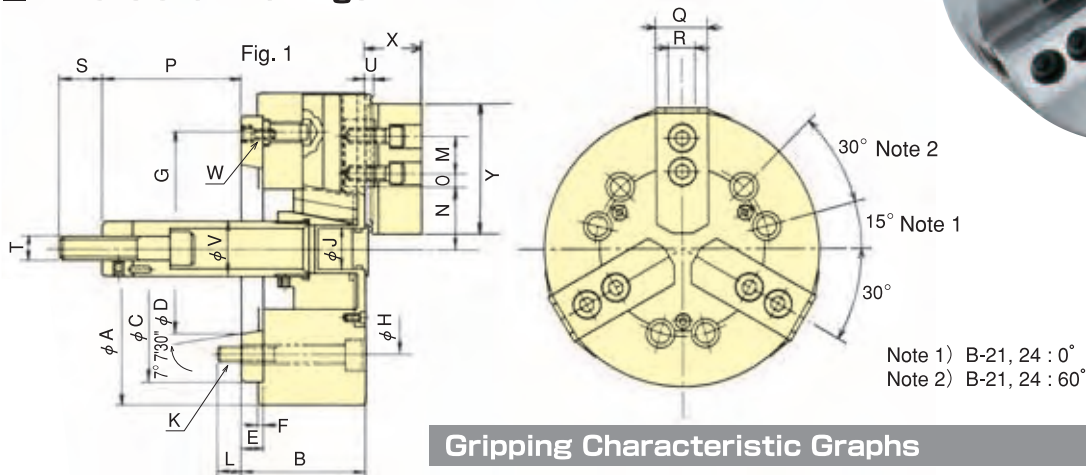

Standard Chuck

Gripping Characteristic Graphs

*With standard blank soft top jaw.

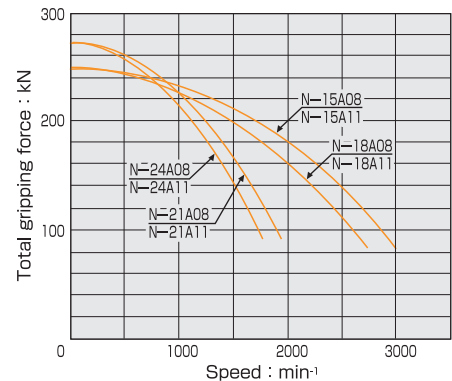
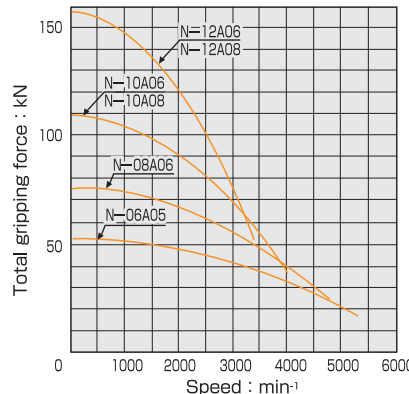

Dimensions *N-10A06, N-12A06, N-15A08, N-18A08, N-21A08, N-21A11, N-24A11 are referred to in Fig-2 *Mounting Bolt P.C.D for N-21A08~N-24A15 : 60° Pitch : 6pcs..

Dimensions	A	B	C	D	E	F	G	H	J	K	L	M	N max.	N min.	O max.	O min.	P max.	P min.	Q	R	S	T	U	V	W	X	Y
N-06A05	165	84	140	82.563	15	5	116	104.8	21	6-M10	14	20	37.8	33.55	13.75	7.75	86.5	66.5	31	12	36	M16	4	34	3-M6	35	72
N-08A06	210	97	170	106.375	17	5	150	133.4	25	6-M12	18	25	46.3	41.9	22.25	11.75	110	89	35	14	36	M20	5	38	3-M6	42	95
N-10A06	254	104	220	106.375	20	5	171.4	133.4	34	6-M12	18	30	51.1	46.7	30.75	11.25	114	89	40	16	36	M20	5	45	6-M16	46	110
N-10A08	254	102	220	139.719	18	5	190	171.4	34	6-M16	25	30	51.1	46.7	30.75	11.25	140	115	40	16	36	M20	5	45	3-M8	46	110
N-12A06	304	120	220	106.375	20	6	171.4	133.4	34	6-M12	18	30	61	55.75	48.75	12.75	119	89	50	18	36	M20	5	50	6-M16	54	129
N-12A08	304	118	220	139.719	18	6	190	171.4	34	6-M16	25	30	61	55.75	48.75	12.75	145	115	50	18	36	M20	5	50	3-M8	54	129
N-15A08	381	130	300	139.719	22	6	235	171.4	-	6-M16	23	43	77.5	69.5	48.75	23.25	82	47	50	25.5	55	M30	2	60	6-M20	61	135
N-15A11	381	130	300	196.869	22	6	260	235	-	6-M20	33	43	77.5	69.5	48.75	23.25	82	47	50	25.5	55	M30	2	60	3-M10	61	135
N-18A08	450	130	300	139.719	22	6	235	171.4	-	6-M16	23	43	108	100	48.75	23.25	70	35	50	25.5	55	M30	2	60	6-M20	61	135
N-18A11	450	130	300	196.869	22	6	260	235	-	6-M20	33	43	108	100	48.75	23.25	70	35	50	25.5	55	M30	2	60	3-M10	61	135
N-21A08	530	146	380	139.719	27	6	330.2	171.4	-	6-M16	23	60	86	78	93.5	27.5	70	35	65	25	55	M30	3	60	6-M22	71	180
N-21A11	530	146	380	196.869	27	6	330.2	235	-	6-M20	28	60	86	78	93.5	27.5	70	35	65	25	55	M30	3	60	6-M22	71	180
N-21A15	530	146	380	285.775	27	6	330.2	330.2	-	6-M22	34	60	86	78	93.5	27.5	70	35	65	25	55	M30	3	60	3-M12	71	180
N-24A11	610	146	380	196.869	27	6	330.2	235	-	6-M20	28	60	125	117	93.5	27.5	70	35	65	25	55	M30	3	60	6-M22	71	180
N-24A15	610	146	380	285.775	27	6	330.2	330.2	-	6-M22	34	60	125	117	93.5	27.5	70	35	65	25	55	M30	3	60	3-M12	71	180

Specifications *Max. speed is shown using actual test data.

Specifications	Gripping range mm	Jaw Stroke (diameter) mm	Plunger Stroke mm	Max. Draw Bar Pull Force kN (kgf)	Max. Gripping Force kN (kgf)	Max. Speed min ⁻¹	Net Weight with Soft top jaws kg	Moment of inertia N·m ² (kg·m ²)	Matching pressure	Cylinder air	Max. pressure MPa(kgf/cm ²)	Matching Hard top jaw	Matching Soft top jaw	Spindle nose size
N-06A05	165	19	8.5	20	18(1835)	525(5353)	5270	14	0.050	Y1020R	2.6(26.5)	HB06B1	SB06B1	A2-5
N-08A06	210	23	8.8	21	25(2549)	75(7648)	4760	27	0.148	Y1225R	2.5(25.5)	HB08A1	SB08B1	A2-6
N-10A06	254	24	8.8	25	29(2957)	108(11013)	4010	40	0.335	Y1225R	2.8(28.6)	HB10A1	SB10B1	A2-6
N-10A08	254	24	8.8	25	29(2957)	108(11013)	4010	40	0.328	Y1225R	2.8(28.6)	HB10A1	SB10B1	A2-8
N-12A06	304	26	10.5	30	41(4181)	156(15907)	3380	67	0.760	Y1530R	2.7(27.5)	HB12B1	SB12A1	A2-6
N-12A08	304	26	10.5	30	41(4181)	156(15907)	3380	66	0.753	Y1530R	2.7(27.5)	HB12B1	SB12A1	A2-8
N-15A08	381	72	16	35	82(8362)	249(25391)	3040	111	2.0	Y2035R	3.2(32.6)	HB15N1	SB15N1	A2-8
N-15A11	381	72	16	35	82(8362)	249(25391)	3040	108	2.0	Y2035R	3.2(32.6)	HB15N1	SB15N1	A2-11
N-18A08	450	133	16	35	82(8362)	249(25391)	2710	136	3.4	Y2035R	3.2(32.6)	HB15N1	SB15N1	A2-8
N-18A11	450	133	16	35	82(8362)	249(25391)	2710	133	3.4	Y2035R	3.2(32.6)	HB15N1	SB15N1	A2-11
N-21A08	530	62	16	35	82(8362)	273(27838)	1940	219	7.5	Y2035R	3.2(32.6)	HB18B2	SB18A2	A2-8
N-21A11	530	62	16	35	82(8362)	273(27838)	1940	216	7.5	Y2035R	3.2(32.6)	HB18B2	SB18A2	A2-11
N-21A15	530	62	16	35	82(8362)	273(27838)	1940	225	7.7	Y2035R	3.2(32.6)	HB18B2	SB18A2	A2-15
N-24A11	610	152	16	35	82(8362)	273(27838)	1760	270	12.4	Y2035R	3.2(32.6)	HB18B2	SB18A2	A2-11
N-24A15	610	152	16	35	82(8362)	273(27838)	1760	263	12.3	Y2035R	3.2(32.6)	HB18B2	SB18A2	A2-15



CHUCK

Large Power Chuck for Vertical Lathes

NV series

Low maintenance Power Chuck for Vertical Lathes Sealed Base Jaw to prevent Swarf and Coolant ingress



- Protection against Swarf and Coolant
Protector and Scraper at Base Jaw prevent Swarf and Coolant ingress.

- Standard Jaw
NV series is compatible with standard Hard and Soft Jaws as sealing is at the Base Jaw.

*CE correspondence

Dimensional Drawings

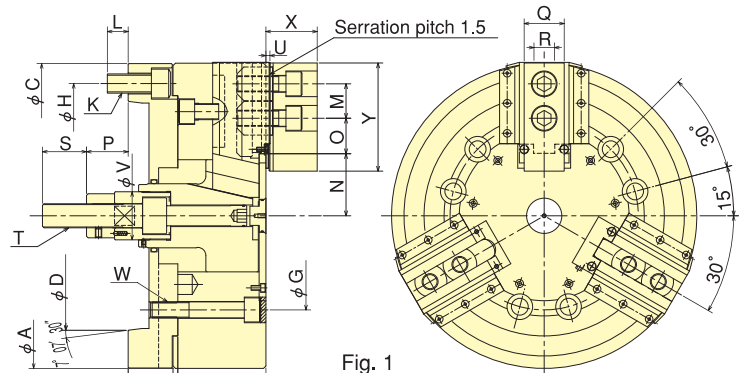

Fig. 1

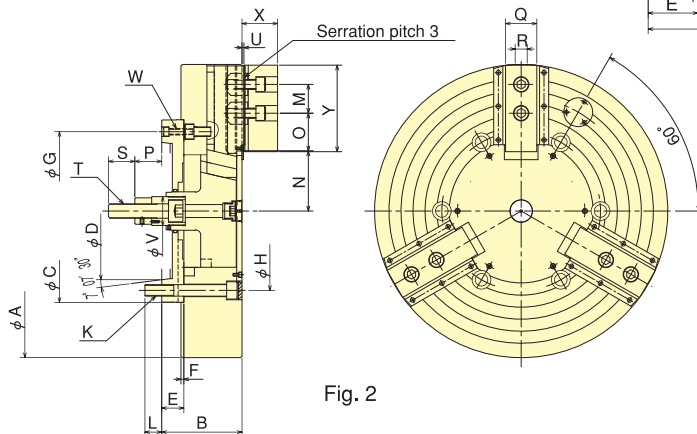
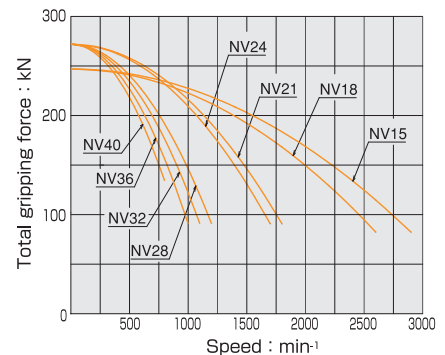

Fig. 2

Gripping Characteristic Graphs

※With standard blank soft top jaw.



Dimensions

※NV15&18 are based on Fig.1. NV21~40 are based on Fig.2.

Model	A	B	C	D	E	F	G	H	K	L	M	N max.	N min.	O max.	O min.	P max.	P min.	Q	R	S	T	U	V	W	X	Y
NV15C15	381	172	380	285.775	62	6	235.0	330.2	6-M24	26	43	77.5	69.5	48.75	23.25	91	56	50	25.5	55	M30	5	60	6-M20	64	135
NV18C15	450	172	380	285.775	62	6	235.0	330.2	6-M24	26	43	108	100	48.75	23.25	91	56	50	25.5	55	M30	5	60	6-M20	64	135
NV21C15	530	167	380	285.775	46	6	330.2	330.2	6-M24	35	60	86	78	93.5	27.5	91	56	65	25.0	55	M30	6	60	3-M12	74	180
NV24C15	610	167	380	285.775	46	6	330.2	330.2	6-M24	29	60	125	117	93.5	27.5	91	56	65	25.0	55	M30	6	60	3-M12	74	180
NV28C15	700	167	380	285.775	46	6	330.2	330.2	6-M24	29	60	125	117	141.5	27.5	91	56	65	25.0	55	M30	6	60	3-M12	74	180
NV32C15	800	167	380	285.775	46	6	330.2	330.2	6-M24	29	60	125	117	189.5	27.5	91	56	65	25.0	55	M30	6	60	3-M12	74	180
NV36C15	914	167	380	285.775	46	6	330.2	330.2	6-M24	29	60	125	117	249.5	27.5	91	56	65	25.0	55	M30	6	60	3-M12	74	180
NV40C15	1000	167	380	285.775	46	6	330.2	330.2	6-M24	29	60	125	117	282.5	27.5	91	56	65	25.0	55	M30	6	60	3-M12	74	180

※The above dimensions are for mounting back plate of 15-nose. The back plate of 11-nose can also be mounted.

Specifications

Model	Gripping range mm Max. Min.	Jaw Stroke (diameter) mm	Plunger Stroke mm	Max. Draw Bar Pull Force kN (kgf)	Max. Gripping Force kN (kgf)	Max. Speed min ⁻¹	Net Weight with Soft top jaws kg	Moment of inertia kg·m ²	Matching Cylinder	Max. pressure MPa (kgf/cm ²)	Matching Soft top jaw	Spindle nose size
NV15C15	381 72	16	35	82 (8362)	247 (25187)	2900	139	2.7	Y2035R	3.2 (32.6)	SB15N1	A ₂ -15
NV18C15	450 133	16	35	82 (8362)	247 (25187)	2600	166	4.1	Y2035R	3.2 (32.6)	SB15N1	A ₂ -15
NV21C15	530 62	16	35	82 (8362)	272 (27736)	1800	227	7.6	Y2035R	3.2 (32.6)	SB18A2	A ₂ -15
NV24C15	610 152	16	35	82 (8362)	272 (27736)	1700	282	12.8	Y2035R	3.2 (32.6)	SB18A2	A ₂ -15
NV28C15	700 152	16	35	82 (8362)	272 (27736)	1200	360	21.9	Y2035R	3.2 (32.6)	SB18A2	A ₂ -15
NV32C15	800 152	16	35	82 (8362)	272 (27736)	1100	472	37.2	Y2035R	3.2 (32.6)	SB18A2	A ₂ -15
NV36C15	914 152	16	35	82 (8362)	272 (27736)	1000	594	62.4	Y2035R	3.2 (32.6)	SB18A2	A ₂ -15
NV40C15	1000 152	16	35	82 (8362)	272 (27736)	800	738	91.5	Y2035R	3.2 (32.6)	SB18A2	A ₂ -15

※The above specifications are for mounting back plate of 15-nose. The back plate of 11-nose can also be mounted.



CHUCK

Closed Centre Power Chuck (Long Stroke) NL series

Extra Long Jaw Stroke Flange work securely gripped

*CE correspondence

Dimensional Drawings

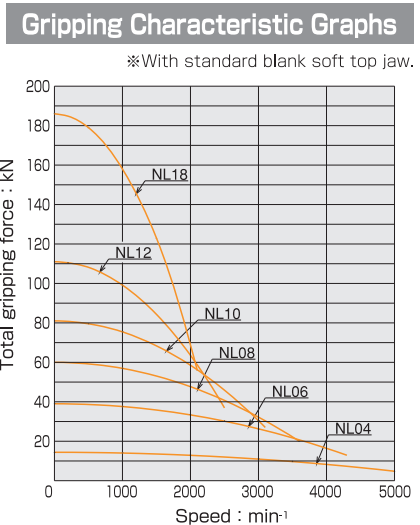
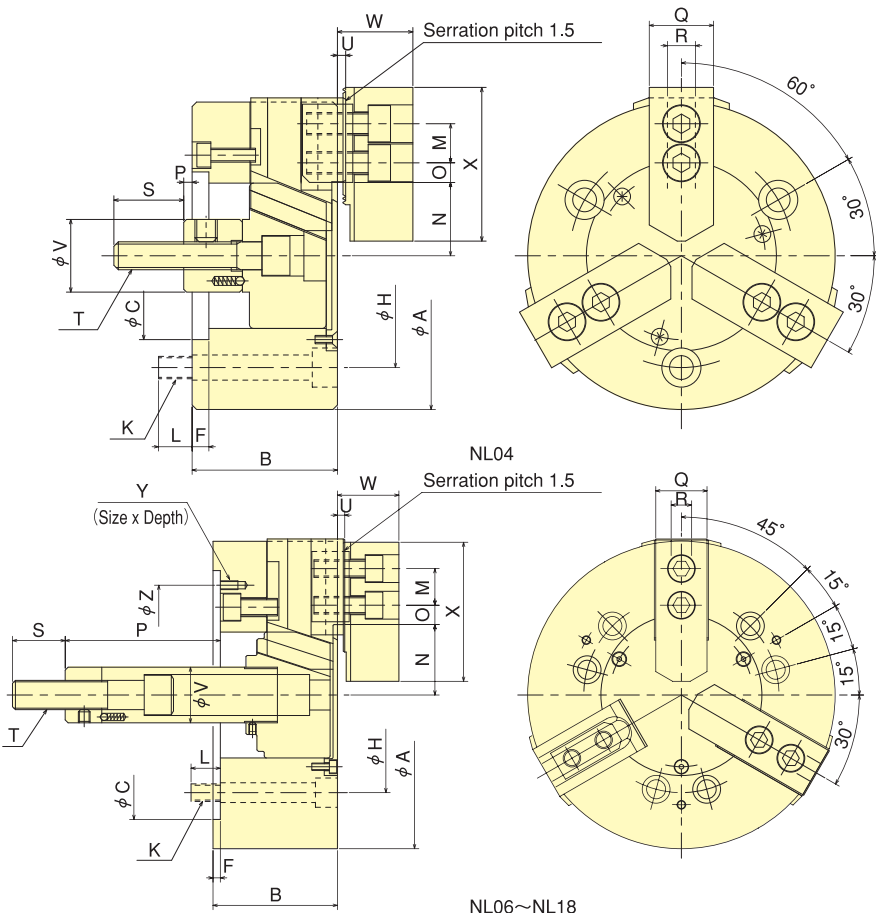

Dimensions

Dimensions Model	A	B	C (H6)	F	H	K	L	M	N max.	N min.	O max.	O min.	P max.	P min.	Q	R	S	T	U	V	W	X	Y	Z
NL04	110	52	60	6	80	3-M 8	12	14	26.5	20.45	9.75	6.75	18	3	23	10	25	M10	3	26	27	55	-	-
NL06	165	74	140	5	104.8	6-M10	14	20	40.5	34	13.75	9.25	101.5	81.5	31	12	36	M16	4	34	35	72	M6 x10	116
NL08	210	85	170	5	133.4	6-M12	20	25	48.1	40	20.75	11.75	131	106	35	14	36	M20	5	38	42	95	M6 x12	150
NL10	254	89	220	5	171.4	6-M16	18	30	54.4	45.35	29.5	11.5	161	133	40	16	36	M20	5	45	46	110	M8 x15	190
NL12	304	106	220	6	171.4	6-M16	18	30	65.7	56	42.75	12.75	47	17	50	18	46	M24	5	50	54	129	M8 x15	190
NL18	450	114	300	6	235	6-M20	30	43	110.5	97.5	47.25	23.25	97	57	50	25.5	55	M30	2	55	61	135	M10 x20	260

Specifications

Specifications Model	Gripping range mm Max.	Gripping range mm Min.	Jaw Stroke (diameter) mm	Plunger Stroke mm	Max. Draw Bar Pull Force kN (kgf)	Max. Gripping Force kN (kgf)	Max. Speed min⁻¹	Net Weight with Soft top jaws kg	Moment of inertia kg·m²	Matching Cylinder	Max. pressure MPa (kgf/cm²)	Matching Soft top jaw	Matching Hard top jaw
NL04	110	6	12.1	15	10 (1020)	14.4 (1468)	5000	4.1	0.008	Y0715R	2.9 (29.6)	SB04B1	-
NL06	165	22	13	20	21 (2141)	39 (3977)	4300	12	0.045	Y1020R	3.0 (30.6)	SB06B1	HB06B1
NL08	210	23	16.2	25	30 (3059)	60 (6118)	3600	22.9	0.138	Y1225R	2.9 (29.6)	SB08B1	HB08A1
NL10	254	27	18.1	28	40 (4079)	81 (8260)	3100	34.6	0.300	Y1530R	2.8 (28.6)	SB10A1	HB10A1
NL12	304	32	19.4	30	54 (5506)	111 (11319)	2500	60	0.725	Y1530R	3.6 (36.7)	SB12A1	HB12B1
NL18	450	124	26	40	91 (9279)	186 (18966)	2100	124	2.35	Y2050R	3.5 (35.9)	SB15N1	-

Standard Chuck



CHUCK

Closed Centre Power Chuck (Long Stroke, Direct Mount)

NL-A series

Chuck Adaptor is equipped to suit Spindle Nose Flange work securely gripped

* CE correspondence



Standard Chuck

Dimensional Drawings

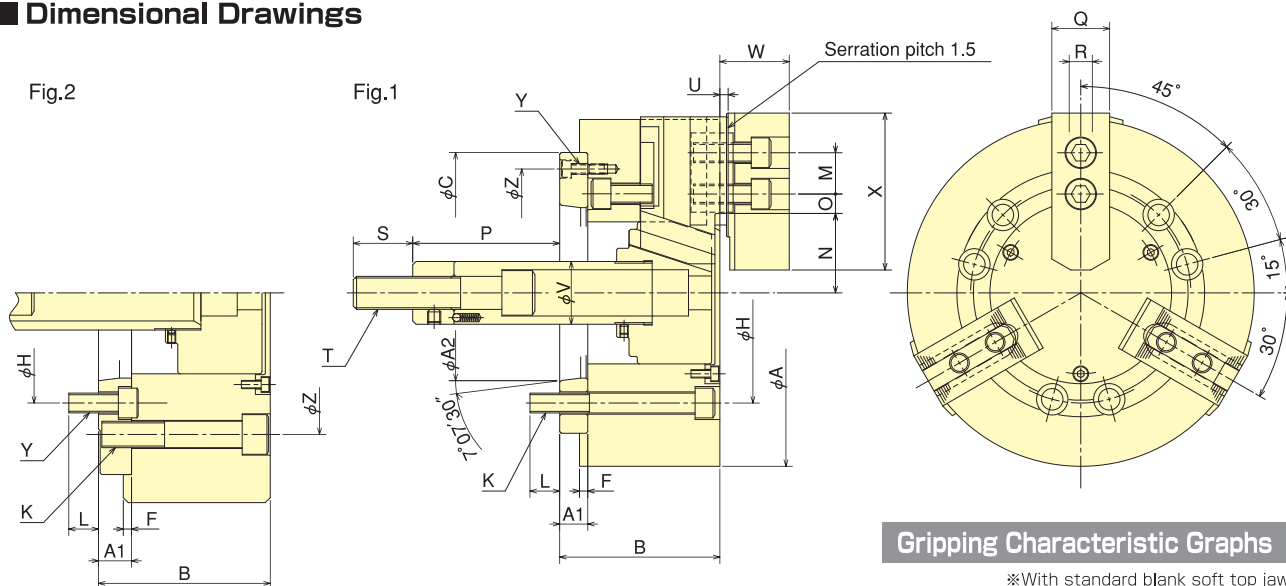

Gripping Characteristic Graphs

*With standard blank soft top jaw.

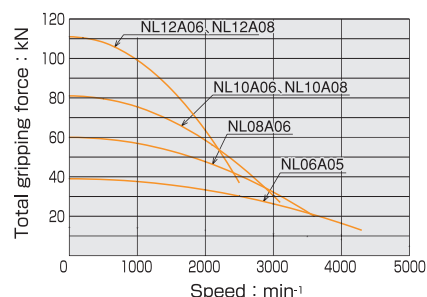

Dimensions *NL10A06 and NL12A06 are based on Fig. 2.

Dimensions Model	A	B	C	F	H	K	L	M	N max.	N min.	O max.	O min.	P max.	P min.	Q	R	S	T	U	V	W	X	Y	Z	A1	A2
NL06A05	165	84	140	5	104.8	6-M10	14	20	40.5	34	13.75	9.25	86.5	66.5	31	12	36	M16	4	34	35	72	3-M6	116	15	82.563
NL08A06	210	97	170	5	133.4	6-M12	18	25	48.1	40	20.75	11.75	114	89	35	14	36	M20	5	38	42	95	3-M6	150	17	106.375
NL10A06	254	104	220	5	133.4	6-M16	18	30	54.4	45.35	29.5	11.5	141	113	40	16	36	M20	5	45	46	110	6-M12	171.4	20	106.375
NL10A08	254	102	220	5	171.4	6-M16	25	30	54.4	45.35	29.5	11.5	143	115	40	16	36	M20	5	45	46	110	3-M8	190	18	139.719
NL12A06	304	120	220	6	133.4	6-M16	18	30	65.7	56	42.75	12.75	3	-27	50	18	46	M24	5	50	54	129	6-M12	171.4	20	106.375
NL12A08	304	118	220	6	171.4	6-M16	25	30	65.7	56	42.75	12.75	1	-29	50	18	46	M24	5	50	54	129	3-M8	190	18	139.719

Specifications

Specifications Model	Gripping range mm		Jaw Stroke (diameter) mm	Plunger Stroke mm	Max. Draw Bar Pull Force kN (kgf)	Max. Gripping Force kN (kgf)	Max. Speed min⁻¹	Net Weight with Soft top jaws kg	Moment of inertia kg·m²	Matching Cylinder	Max. pressure MPa (kgf/cm²)	Matching Soft top jaw	Matching Hard top jaw	Spindle nose size
	Max.	Min.												
NL06A05	165	22	13	20	21 (2141)	39 (3977)	4300	12.5	0.048	Y1020R	3.0 (30.6)	SB06B1	HB06B1	A2-5
NL08A06	210	23	16.2	25	30 (3059)	60 (6118)	3600	24.5	0.148	Y1225R	2.9 (29.6)	SB08B1	HB08A1	A2-6
NL10A06	254	27	18.1	28	40 (4079)	81 (8260)	3100	40	0.335	Y1530R	2.8 (28.6)	SB10A1	HB10A1	A2-6
NL10A08	254	27	18.1	28	40 (4079)	81 (8260)	3100	37.6	0.326	Y1530R	2.8 (28.6)	SB10A1	HB10A1	A2-8
NL12A06	304	32	19.4	30	54 (5506)	111 (11319)	2500	64.6	0.759	Y1530R	3.6 (36.7)	SB12A1	HB12B1	A2-6
NL12A08	304	32	19.4	30	54 (5506)	111 (11319)	2500	63	0.750	Y1530R	3.6 (36.7)	SB12A1	HB12B1	A2-8



CHUCK

Mega-Long Stroke Chuck ML series

Exceptionally long Jaw stroke
Suitable for Multi-Diameter gripping and flange work

* CE correspondence



Standard Chuck

Gripping Example

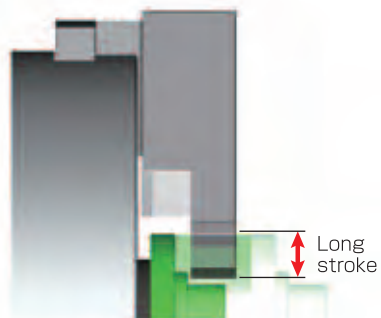

● Suitable for works with large flange

Gripping Characteristic Graphs

*With standard blank soft top jaw.

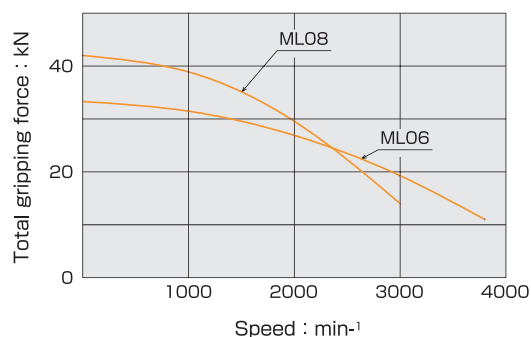

Dimensional Drawings

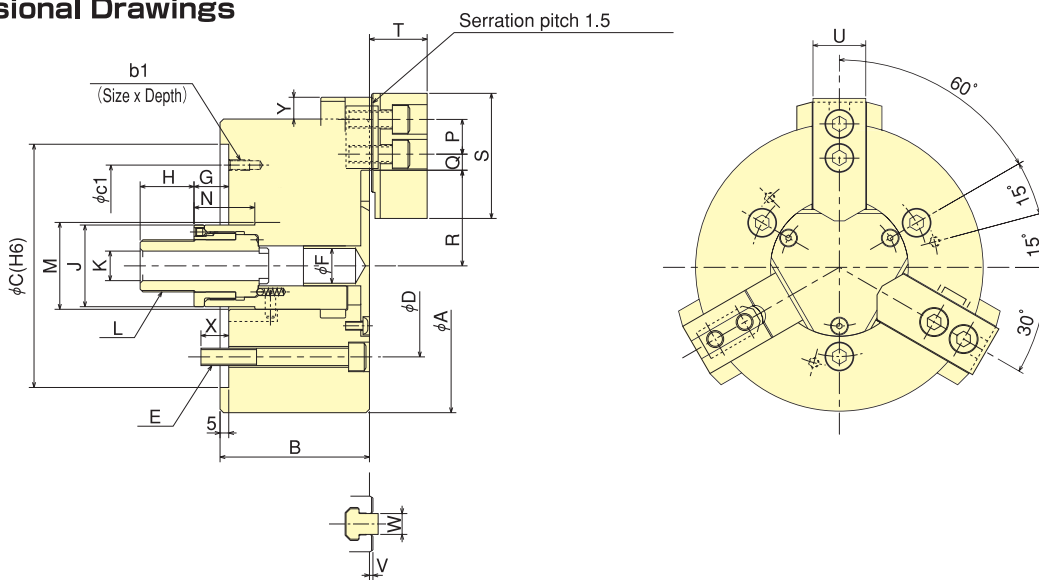

Dimensions

Model	A	B	C	D	E	F	G max.	G min.	H	J	K	L	M	N	P	Q max.	Q min.
ML06	169	86	140	104.8	3-M10	20	40	20	31	47	17	M30×1.5	50	35	20	13.75	9.25
ML08	215	99	170	133.4	3-M12	20	34	9	34	54	17	M33×1.5	70	29	25	17.75	11.75

Model	R max.	R min.	S	T	U	V	W	X	Y max.	b1	c1
ML06	55	35	72	33.2	31	2	12	16	12.5	3-M6×12	116
ML08	65.6	40.6	95	39.2	35	2	14	21	12.1	3-M6×12	150

Specifications

Model	Gripping range mm	Jaw Stroke (diameter) mm	Plunger Stroke mm	Max. Draw Bar Pull Force kN (kgf)	Max. Gripping Force kN (kgf)	Max. Speed min ⁻¹	Net Weight with Soft top jaws kg	Moment of inertia kg·m ²	Matching Cylinder	Max. pressure MPa (kgf/cm ²)	Matching Soft top jaw
ML06	Max. 169 Min. 55	40	20	36.0 (3671)	33.0 (3365)	3800	13.7	0.048	Y1225R	3.46 (35.3)	SB06B1
ML08	Max. 215 Min. 54	50	25	45.0 (4589)	42.0 (4283)	3000	26.0	0.167	Y1530R	3.06 (31.2)	SB08B1



CHUCK

2-Jaw Closed Center Power Chuck (NLT-Long Stroke)

NT·NLT series

Best suited for gripping Irregular shaped components

* CE correspondence



Dimensional Drawings

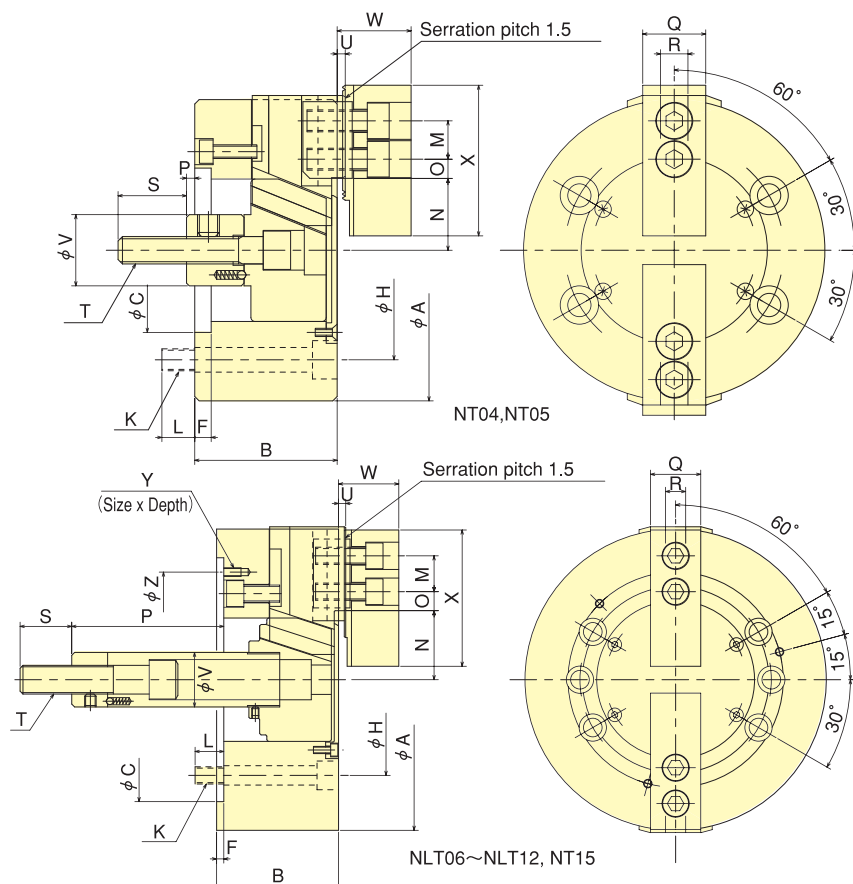

Gripping Characteristic Graphs

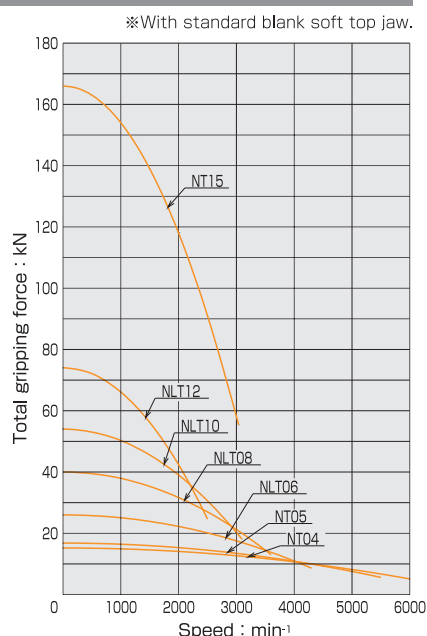

Dimensions

Dimensions Model	A	B	C (H6)	F	H	K	L	M	N max.	N min.	O max.	O min.	P max.	P min.	Q	R	S	T	U	V	W	X	Y	Z
NT04	110	52	60	6	80	4-M8	12	14	23.3	20.1	10.25	8.75	18	3	23	10	25	M10	3	26	27	55	-	-
NT05	135	55	80	7	100	4-M8	14	19	30.4	27.2	11.5	7	9	-6	23	10	35	M12	3	28	29	62	-	-
NLT06	165	74	140	5	104.8	6-M10	14	20	40.5	34	13.75	9.25	101.5	81.5	31	12	36	M16	4	34	35	72	M6 x 10	116
NLT08	210	85	170	5	133.4	6-M12	20	25	48.1	40	21	12	131	106	35	14	36	M20	5	38	42	95	M6 x 12	150
NLT10	254	89	220	5	171.4	6-M16	18	30	54.4	45.35	29.5	11.5	161	133	40	16	36	M20	5	45	46	110	M8 x 15	190
NLT12	304	106	220	6	171.4	6-M16	18	30	65.7	56	42.75	12.75	163	133	50	18	36	M20	5	50	54	129	M8 x 15	190
NT15	381	114	300	6	235	6-M20	30	43	77.5	69.5	48.75	23.25	104	69	50	25.5	55	M30	2	55	61	135	M10 x 20	260

Specifications

※Max. speed is shown using actual test data.

Specifications Model	Gripping range mm		Jaw Stroke (diameter) mm	Plunger Stroke mm	Max. Draw Bar Pull Force kN (kgf)	Max. Gripping Force kN (kgf)	Max. Speed min ⁻¹	Net Weight with Soft top jaws kg	Moment of inertia kg·m ²	Matching Cylinder	Max. pressure MPa (kgf/cm ²)	Matching Soft top jaw
NT04	110	5	6.4	15	5.3 (540)	15.2 (1550)	6000	3.8	0.007	Y0715R	1.68 (17.1)	SB04A1T
NT05	135	16	6.4	15	5.3 (540)	16.8 (1713)	5500	5.8	0.013	Y0715R	1.68 (17.1)	SB05A1T
NLT06	165	22	13	20	14 (1428)	26 (2651)	4300	12.5	0.043	Y1020R	2.06 (21.0)	SB06A1T
NLT08	210	24	16.2	25	20 (2039)	40 (4079)	3600	24	0.133	Y1225R	2.03 (20.7)	SB08A1T
NLT10	254	27	18.1	28	27 (2753)	54 (5506)	3100	35.5	0.293	Y1530R	1.93 (19.7)	SB10A1T
NLT12	304	33	19.4	30	36 (3671)	74 (7546)	2500	60.5	0.708	Y1530R	2.50 (25.5)	SB12A1T
NT15	381	72	16	35	54.7(5578)	166 (16927)	3040	93	1.790	Y2035R	2.1 (21.4)	SB15N1T

※Altering Back Plate enables to change over 3-Jaw Chuck into 2-Jaw Chuck.



CHUCK

2-Jaw Mega-Long Stroke Chuck MLT series

Exceptionally long Jaw stroke
Best suited for gripping irregular shaped components

* CE correspondence



Standard Chuck

Gripping Example

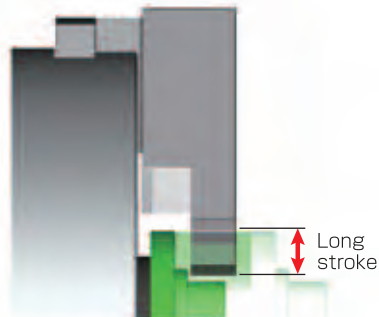

- Suitable for machining of valves.
Common jaw sets can be used due to long stroke.

Gripping Characteristic Graphs

※With standard blank soft top jaw.

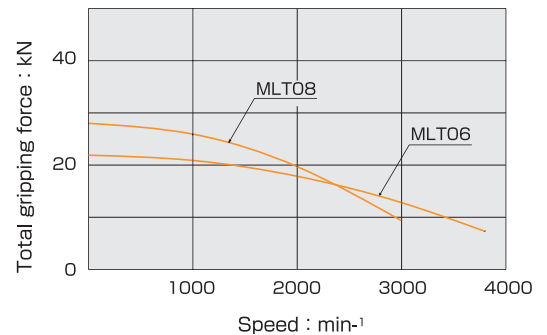

Dimensional Drawings

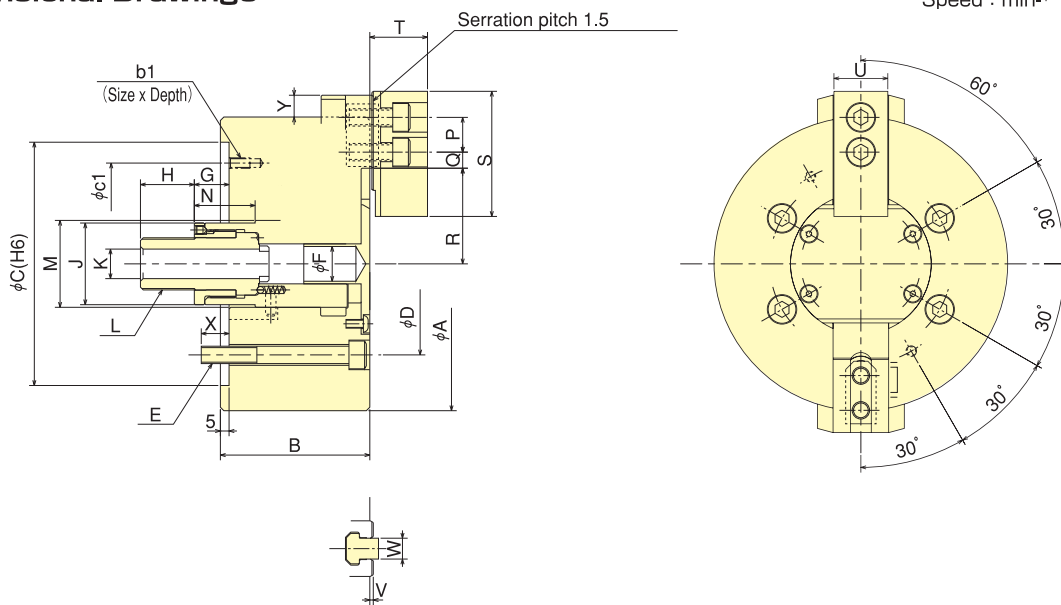

Dimensions

Model	A	B	C	D	E	F	G max.	G min.	H	J	K	L	M	N	P	Q max.	Q min.
MLT06	169	86	140	104.8	4-M10	20	40	20	31	47	17	M30×1.5	50	35	20	13.75	9.25
MLT08	215	99	170	133.4	4-M12	20	34	9	34	54	17	M33×1.5	70	29	25	18	12

Model	R max.	R min.	S	T	U	V	W	X	Y max.	b1	c1
MLT06	55	35	72	33.2	31	2	12	16	12.5	2-M6×12	116
MLT08	65.6	40.6	95	39.2	35	2	14	21	12.1	3-M6×12	150

Specifications

Model	Gripping range mm	Jaw Stroke (diameter) mm	Plunger Stroke mm	Max. Draw Bar Pull Force kN (kgf)	Max. Gripping Force kN (kgf)	Max. Speed min ⁻¹	Net Weight with Soft top jaws kg	Moment of inertia kg·m ²	Matching Cylinder	Max. pressure MPa (kgf/cm ²)	Matching Soft top jaw
MLT06	169 40	40	20	24 (2447)	21.9 (2230)	3800	13.7	0.054	Y1225R	2.39 (24.4)	SB06A1T
MLT08	215 44	50	25	30 (3059)	28 (2855)	3000	25.7	0.164	Y1530R	2.13 (21.7)	SB08A1T

※Altering Back Plate enables to change over 3-Jaw Chuck into 2-Jaw Chuck.



CHUCK

1-Jaw Mega-Long Stroke Chuck MLV series

Exceptionally long Jaw stroke
Best suited for jig work fixturing

*CE correspondence



Gripping Example

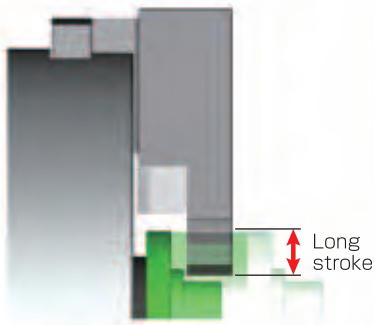

● Halve the set-up time and increase performance.

Gripping Example

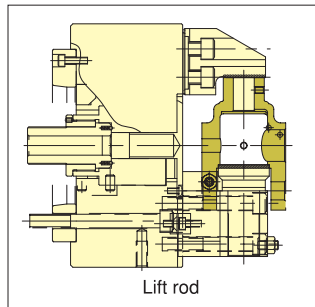

Gripping Characteristic Graphs

※With standard blank soft top jaw.

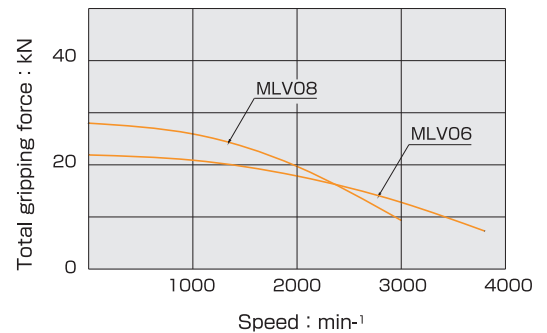

Dimensional Drawings

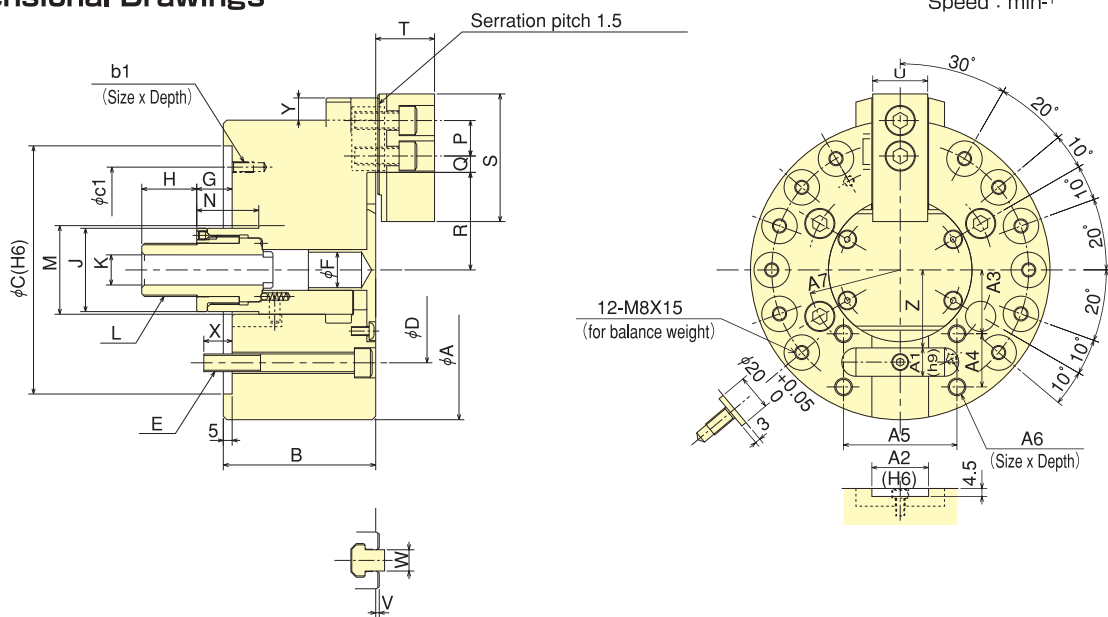

Dimensions

Model	A	B	C	D	E	F	G max.	G min.	H	J	K	L	M	N	P	Q max.	Q min.
MLV06	169	86	140	104.8	4-M10	20	40	20	31	47	17	M30×1.5	50	35	20	13.75	9.25
MLV08	215	99	170	133.4	4-M12	20	34	9	34	54	17	M33×1.5	70	29	25	18	12

Model	R max.	R min.	S	T	U	V	W	X	Y max.	Z	A1	A2	A3	A4	A5	A6	A7	b1	c1
MLV06	55	35	72	33.2	31	2	12	16	12.5	44	16	32	36	30	64	4-M10×16	72.5	2-M6×12	116
MLV08	65.6	40.6	95	39.2	35	2	14	21	12.1	60	18	37	51	36	70	4-M12×20	95	3-M6×12	150

Specifications

Model	Gripping range mm	Jaw Stroke mm	Plunger Stroke mm	Max. Draw Bar Pull Force kN (kgf)	Max. Gripping Force kN (kgf)	Max. Speed min⁻¹	Net Weight with Soft top jaws kg	Moment of inertia kg·m²	Matching Cylinder	Max. pressure MPa (kgf/cm²)	Matching Soft top jaw
MLV06	Max. 169 Min. 40	20	20	12.0 (1224)	21.9 (2230)	3800	13.2	0.050	Y1225R	1.32 (13.5)	SB06A1V
MLV08	Max. 215 Min. 44	25	25	15.0 (1530)	28.0 (2855)	3000	25.0	0.155	Y1530R	1.19 (12.3)	SB08A1V



CHUCK

4-Jaw Lever Type Power Operated Chuck with Closed Centre HW series

**Steadily grips block, oval, or any irregular shaped works
Self Centring Mechanism (2+2 Jaws)**



Standard Chuck

● Self Centring Mechanism

2 independent Jaw sets give Dual Action clamping allowing irregular shapes to be easily gripped. Consequently, it is the best to chuck a deformed work such as a square shape and elliptical shape.

● Long Stroke

Long Jaw Stroke ensures components with variation are gripped securely.

*CE correspondence

■ Dimensional Drawings

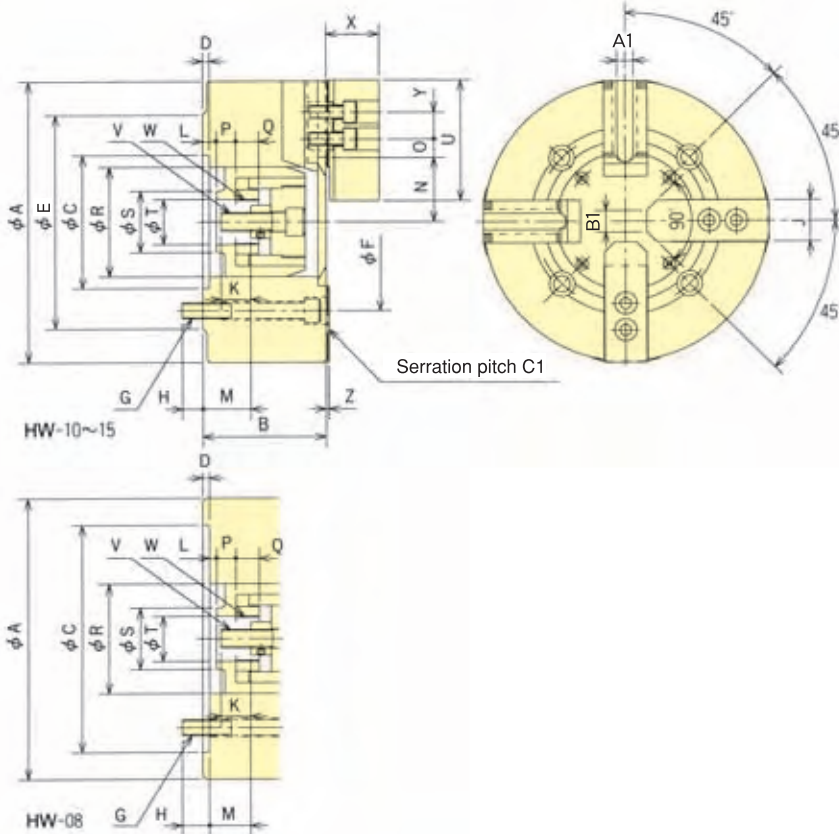

Gripping Example

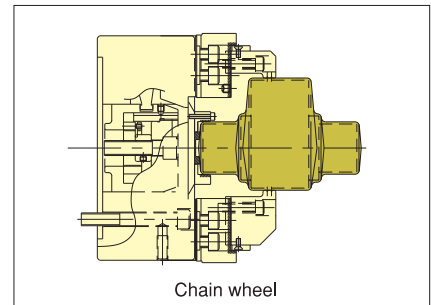

Gripping Characteristic Graphs

*With standard blank soft top jaw.

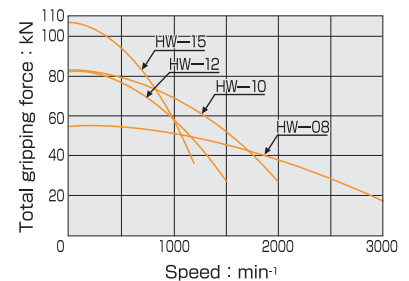

■ Dimensions

Model	A		B		C (H6)		D	E	F	G	H	J	K	L		M		N		O		P	Q	R	S	T	U	V	W	X	Y	Z	A1	B1	C1
	max.	min.	max.	min.	max.	min.								max.	min.	max.	min.																		
HW-08	210	91	170	5	-	133.4	4-M12	20	31	29	10.5	-6.5	39	22	50.3	43.7	26.75	9.25	17.5	17	82	46	34	90	M14x20	M34x1.5	39	20	2	12	16	1.5			
HW-10	270	110	120	5.5	200	170	4-M16	24	40	31	18	-4	49	27	64	56	28	13	20	20	103	58	42	110	M16x20	M42x1.5	45	30	5	16	-	3.0			
HW-12	304	110	120	5.5	200	170	4-M16	24	40	31	18	-4	49	27	64	56	49	13	20	20	103	58	42	110	M16x20	M42x1.5	45	30	5	16	-	3.0			
HW-15	381	135	195	7.5	285	235	4-M20	30	50	55	26	1	59.5	34.5	78	69.5	66.5	12.5	18.5	24	130	78	55	129	M20x25	M55x2	53	38	5	18	-	3.0			

■ Specifications

Model	Gripping range mm		Jaw Stroke (diameter) mm	Plunger Stroke mm	Max. Draw Bar* (Per of Plunger) kN (kgf)	Max. Gripping Force* (Per of Jaw) kN (kgf)	Max. Speed min⁻¹	Net Weight with Soft top jaws kg	Moment of inertia kg·m²	Matching Cylinder	Max. pressure MPa(kgf/cm²)	Matching Soft top jaw
	Max.	Min.										
HW-08	210	26	13.2	17	16.5 (1683)	28 (2855)	3000	23	0.153	YW1220R	1.71 (17.4)	SB08A2Q
HW-10	270	54	16	22	23 (2345)	42 (4283)	2000	50	0.500	YW1225R	2.29 (23.4)	SB10A2Q
HW-12	304	54	16	22	23 (2345)	42 (4283)	1500	58	0.700	YW1225R	2.29 (23.4)	SB10A2Q
HW-15	381	63	17	25	28 (2855)	54 (5506)	1200	118	2.25	YW1225R	2.73 (27.8)	SB15A2Q

*In chuck total, both maximum allowable input value and static gripping force value are double on the above list.

*The movement order of jaw cannot be assigned in combination with YW cylinder. (Contact to Kitagawa when assignment is required.)



CHUCK

3-Jaw Air-Operated Self Contained Chuck UVE-K series

Built-in Pneumatic Cylinder

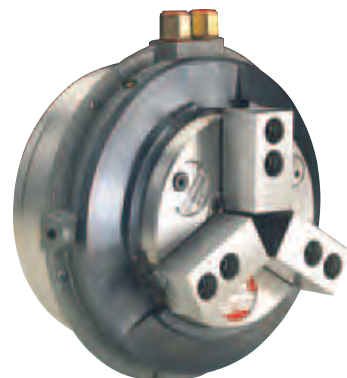

Dimensional Drawings

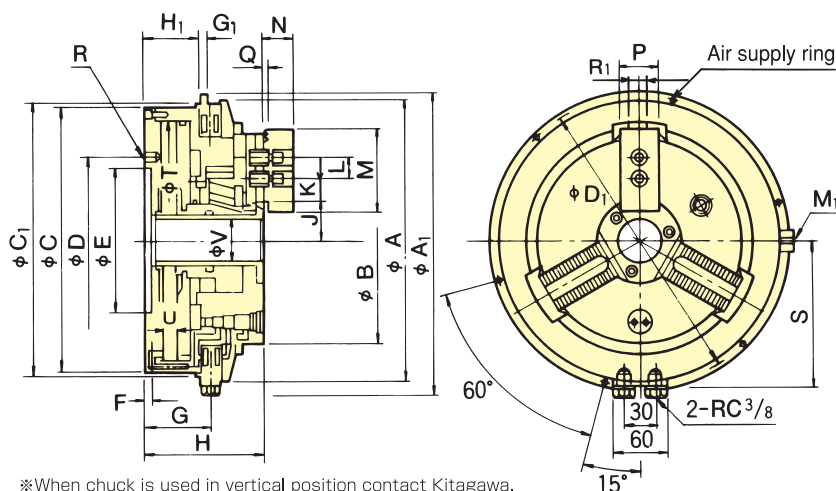

※When chuck is used in vertical position contact Kitagawa.

Gripping Characteristic Graphs

※Each curve shows air pressure 0.6MPa (6.1kgf/cm²). This is a case that standard soft jaws are used.

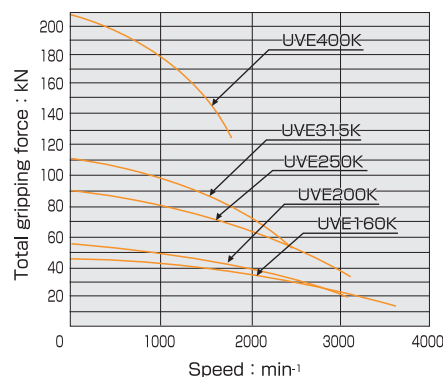

Dimensions

Mode	A	B	C	D	E (H7)	F	G	H	J max.	J min.	K max.	K min.	L	M	N	P	Q	R	S	T	U	V	A ₁	C ₁ (h6)	D ₁	G ₁	H ₁ ±0.1	M ₁	R ₁
UVE160K	250	170	230	180	160	6.5	83	137	33.5	29.3	19.25	10.25	25	76.5	38.5	40	2.25	6-M10	138	205	24	38	273	240	260	6	71	M10	14
UVE200K	280	200	260	210	185	8	82.5	141	43	38.8	20.25	11.25	30	110	43	40	2.25	6-M10	150	230	24	50	302	275	288	6	69	M10	16
UVE250K	330	250	310	260	235	8	87.5	151	47.5	42.6	39.75	12.75	30	110	43	40	2.25	6-M10	175	280	28	60	350	320	336	6	74	M12	16
UVE315K	385	315	365	315	290	8	90.5	155	64	59.1	46.25	14.75	38	129	51	50	2.25	6-M10	206	335	28	92	410	380	395	8	77	M12	18
UVE400K	495	400	475	340	300	8	118	200	86	79	37.5	16.5	60	156	71	62	3.3	6-M16	257	440	40	120	518	485	505	8	104	M16	22

Specifications

Mode	Thru-Hole mm	Gripping range mm	Jaw Stroke (diameter) mm	Plunger Stroke mm	Max. Gripping Force (at air pressure 0.6MPa (6.1kgf/cm ²)) kN (kgf)	Max. Speed min ⁻¹	Net Weight kg	Moment of inertia kg·m ²	Matching Soft top jaw	Max. pressure MPa	Air consumption per 10mm (at air pressure 6.1kgf/cm ²)	Serration pitch
UVE160K	38	170 18	8.4	24	45 (4588)	3600 (3500)	29.5	0.25	SB06C1	0.6 (6.1)	2.375	1.5
UVE200K	50	200 18	8.4	24	54 (5506)	3200 (2800)	38.5	0.35	SB10B1	0.6 (6.1)	2.990	1.5
UVE250K	60	250 18	9.8	28	90 (9177)	3000 (2200)	61	0.725	SB10B1	0.6 (6.1)	4.432	1.5
UVE315K	92	315 48	9.8	28	111 (11318)	2500 (1800)	81	1.45	SB12C1	0.6 (6.1)	6.343	1.5
UVE400K	120	400 90	14	40	210 (21413)	1800 (1200)	145	4.375	SB15A2	0.6 (6.1)	10.943	3

※Maximum speed is shown with each value under air pressure of 0.6MPa, using standard soft jaw and fixed air supply ring. If the supply ring is not fixed, each value in () is applied.

※Gripping force of a jaw is one third of max. gripping force.
 ※Standard accessories : Soft jaw, air pressure gauge, tools of a set.

Hard Jaw (Option accessories)

Model	Gripping range mm	Hard jaw
UVE160K	φ12~φ170	HBO6U1
UVE200K	φ14~φ180	HBO8U1
UVE250K	φ21~φ225	HBO8U1
UVE315K	φ36~φ310	HB12U1
UVE400K	φ80~φ400	HB16U2

※Hard jaw for UVE200K & 250K is same.
 ※Hard jaw for UVE500K size or more is manufactured under prearrangement.

Recommended air circuit diagram

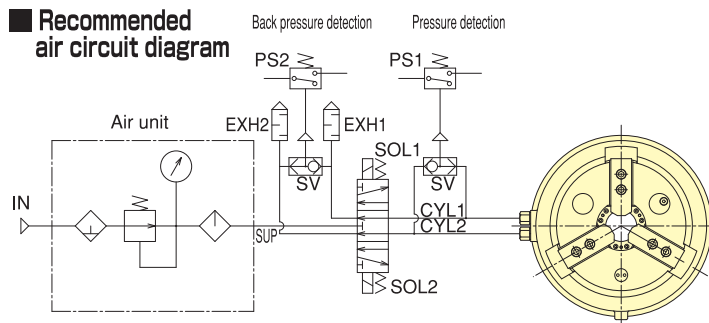



CHUCK

3-Jaw Air-Operated Self Contained Chuck UB series

Built-in Pneumatic Cylinder Large chuck best suited for pipe processing



Standard Chuck

- The jaw position can be detected
- Internal pressure can be detected
- * CE correspondence

Dimensional Drawings

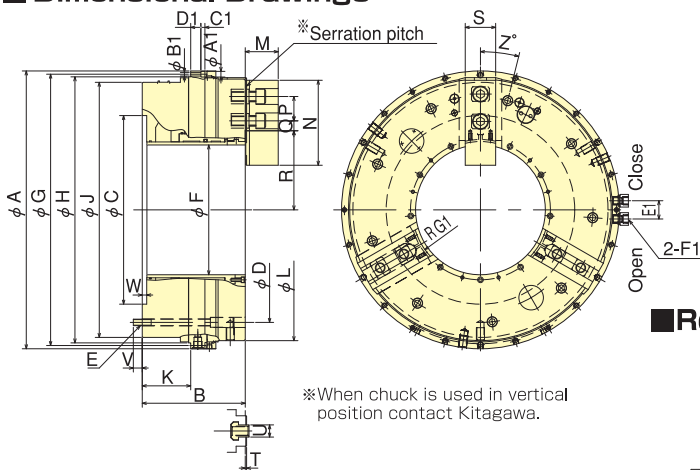

Recommended Air Circuit Diagram

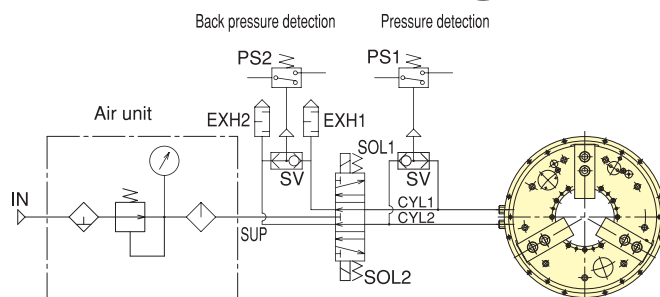

Dimensions

Model	A1	B1	C1	D1	E1	F1	G1
UB450K/P	11	6.6	6.6	25	45	Rc3/8	87.5
UB560K/P	14	9	9	20	45	Rc1/2	134
UB630K/P	14	9	10	25	45	Rc1/2	160
UB710K/P	17	11	11	33	45	Rc1/2	185

*Serration pitch Model UBxxxK : mm, UBxxxP : inch

Model	A		B		C (H7)		D	E	F	G	H (H7)		J	K	L	M		N	P	Q max.	Q min.	R max.	R min.	S	T	U	V	W	Z
	mm	inch	mm	inch	mm	inch					mm	inch																	
UB450K/P	494	212	275	373	9-M12	181	481	470	431	98.5	441	67.3	68.7	165	43	41.5	17.5	121.4	114.4	62	3.3	25.5	17	6	20				
UB560K/P	626	230	375	485	6-M16	275	610	595	556	113.5	568	70.5	71.9	180	60	42	18	169	160.5	65	3.3	25.5	24	11	40				
UB630K/P	698	254	465	555	9-M16	320	682	669	629	119.5	645	81.3	82.7	209.5	60	50.5	23.5	195	186.5	75	3.3	30	22	11	14				
UB710K/P	790	252	520	620	9-M16	375	770	745	702	118.5	714	81.3	82.7	209.5	60	62.3	26.3	222.5	211.5	75	3.3	30	24	11	24				

Specifications

Model	Thru-Hole mm	Gripping range mm Max. Min.	Jaw Stroke (diameter) mm	Plunger Stroke mm	Max. Gripping Force kN (kgf)	Max. Speed min ⁻¹	Net Weight with Soft top jaws kg	Moment of inertia kg·m ²	Max pressure MPa (kgf/cm ²)	Air consumption per 10mm (at air pressure 0.6MPa (6.1kgf/cm ²))
UB450K/P	181	441 120	14	40	100 (10200)	1300	204	5.55	0.6 (6.1)	4.83
UB560K/P	275	568 220	17	37	120 (12230)	1100	320	15.8	0.6 (6.1)	7.17
UB630K/P	320	645 225	17	37	162 (16520)	1000	480	28.1	0.6 (6.1)	9.27
UB710K/P	375	714 275	22	36	144 (14680)	900	550	38.9	0.6 (6.1)	11.10

*Maximum speed is shown with each value under air pressure of 0.6MPa, using standard soft jaw and fixed air supply ring. If the supply ring is not fixed, each value in () is applied.
 *Gripping force of a jaw is one third of max. gripping force. *Standard accessories : Soft jaw, air pressure gauge, tools of a set.
 *The work of diameter smaller than the above minimum gripping diameter can be gripped by using a collet pad (option).

AVF-3-FL type manual change valve (Special accessories)

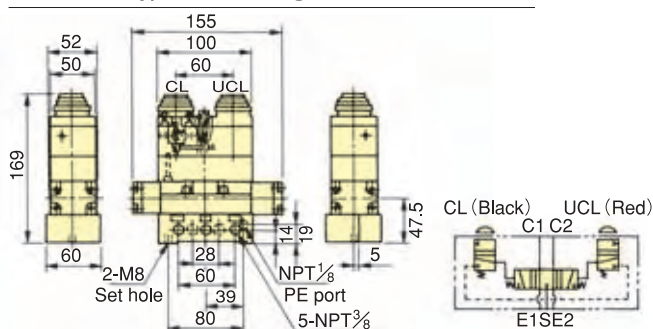

This valve is light-weight, compact and can be operated with the press of a button. The simple piping can be routed when the selector is mounted on the lathe. The valve is the exhaust centre type and designed for exclusive UB types.

Pressure	0~1MPa (10.1kgf/cm ²)
Proof pressure	1.5MPa (15.3kgf/cm ²)
Push button operation force	4kg
Connection bore	Rc3/8



CHUCK

3-Jaw Air-Operated Self Contained Chuck UPR series

Air-operated chuck perfect for oil pipe standards

- Easy installation
- Easy centering adjustment
- Service & maintenance improved.
Easy replacing consumable parts



Dimensional Drawings

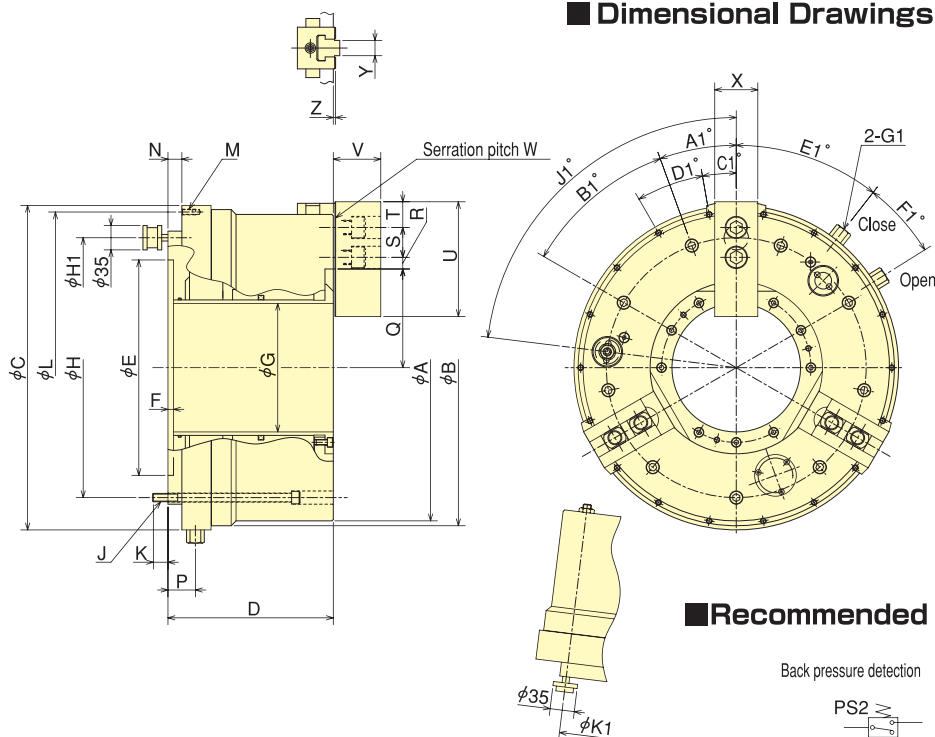

Recommended air circuit diagram

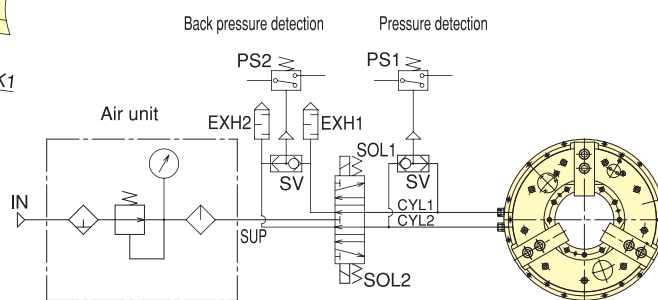

Dimensions

Model	A	B	C (0-0.2)	D	E (H7)	F	G	H	J	K	L
UPR450	441	455	467	238	310	8	185	374	9-M12	22	448
UPR600	590	605	605	272	450	8	275	508	12-M12	22	585
UPR650	655	675	685	283	510	8	325	580	12-M16	24	666
UPR710	715	740	750	283	550	8	375	620	9-M16	24	730
UPR910	915	915	925	291	700	10	560	800	12-M16	26	905

Model	M	N	P	Q max.	Q min.	R max.	R min.	S	T	U	V	W	X	Y (h8)	Z	A1	B1	C1	D1	E1	F1	G1	H1	J1	K1
UPR450	18-M8 Depth 20	20	39.5	142	122	34.75	16.75	43	37	165	68.3	1.5	62	22	3.3	20°	9x40°	10°	18x20°	38°	20°	Rc3/8	374	83°	374
UPR600	18-M8 Depth 20	20	50	196.5	171.5	32.5	20.5	60	39.5	180	70.5	3	65	25.5	3.3	15°	12x30°	0°	18x20°	25°	20°	Rc3/8	508	60°	508
UPR650	18-M8 Depth 20	20	50	223	198	38.5	20.5	60	40	209.5	81.3	3	75	30	3.3	15°	12x30°	0°	18x20°	25°	20°	Rc1/2	580	60°	580
UPR710	18-M8 Depth 20	20	43	248	223	50.5	23.5	60	40	209.5	81.3	3	75	30	3.3	20°	9x40°	0°	18x20°	30°	15°	Rc1/2	620	45°	620
UPR910	18-M8 Depth 20	33	56	342	317	50.5	23.5	60	40	209.5	81.3	3	75	30	3.3	15°	12x30°	0°	18x20°	30°	15°	Rc1/2	800	60°	800

Specifications

Model	Thru-Hole mm	Gripping range mm		Jaw Stroke (diameter) mm		Plunger Stroke mm	Max. Gripping Force kN (kgf)	Max. Speed min ⁻¹	Net Weight kg	Moment of inertia kg·m ²	Max. pressure MPa
		Max.	Min.	Rapid	Gripping						
UPR450	185	441	127	26	14	53	100(10197)	1300	195	5.5	0.6
UPR600	275	590	235	33	17	53.5	120(12236)	1100	365	19.7	0.5
UPR650	325	655	240	33	17	53.5	147(14990)	1000	476	32.2	0.6
UPR710	375	715	294	33	17	53.5	162(16519)	900	532	43.1	0.6
UPR910	560	915	475	33	17	53.5	162(16519)	600	735	103	0.5



CHUCK

3-Jaw Ultra High Precision Air Chuck KPC series

High Repeatability

Optimum KPC chuck for finishing and precision processes



Standard Chuck

● Built-in Pneumatic Cylinder

Dimensional Drawings

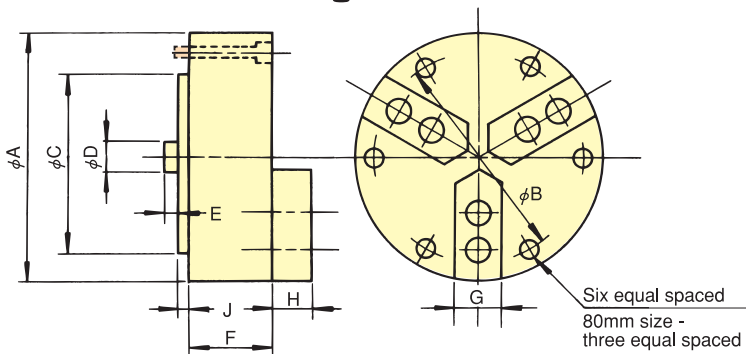

Gripping Characteristic Graphs

※ Each curve shows air pressure 0.7MPa (7.1kgf/cm²). This is a case that standard soft jaws are used.

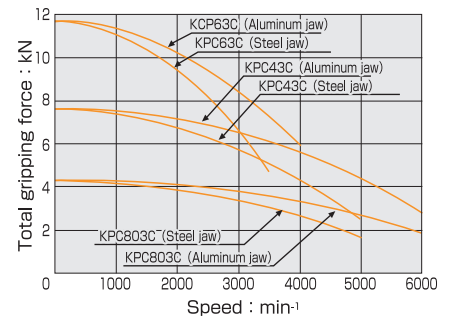

Dimensions

Dimensions model	A	B	C (h6)	D	E max.	E min.	F	G	H	J	Jaw Mounting bolts	Mounting bolts	Net Weight with Soft top jaws kg
KPC803C100	80	70	60	20.6	17	9.9	55	20	19	2	3-M5×16	3-M5×60	1.8
KPC43C048	100	88.9	82.55	20.6	18.8	15.3	50.5	20	19	2	3×2-M5×16	6-M5×55	2.1
KPC43C100	100	88.9	82.55	20.6	18	10.8	55	20	19	2	3×2-M5×16	6-M5×60	2.1
KPC63C100	150	135.8	124.97	20.6	17.6	10.4	56	25	19	2	3×4-M5×16	6-M6×65	6.3

Specifications

model	Specifications	Repeatability mm	Number of Jaws	Jaw Stroke (diameter) mm	Gripping range		Max. Gripping Force kN (kgf) (Air pressure 0.7MPa)	Max. Speed (with std. Aluminum jaw) min ⁻¹
					external φ	Internal φ		
KPC803C100P		0.0025	3	2.5	3~70	6~79	4.3 (438)	6000
KPC803C100EP		0.0013						
KPC803C100EP1		0.0010						
KPC43C048P		0.0025	3	1.2	3.5~87	6~99	7.6 (775)	6000
KPC43C048EP		0.0013						
KPC43C048EP1		0.0010						
KPC43C100P		0.0025	3	2.5	3~87	6~99	7.6 (775)	6000
KPC43C100EP		0.0013						
KPC43C100EP1		0.0010						
KPC63C100P		0.0025	3	2.5	3~135	6~149	11.6 (1183)	4000
KPC63C100EP		0.0013						
KPC63C100EP1		0.0010						

Ordering length of air feed tube (option)

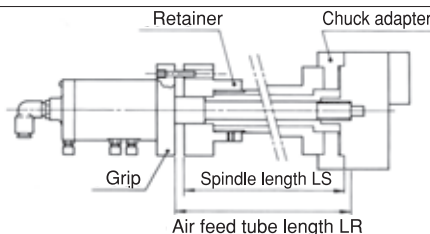

When ordering the air feed tube (coolant or non-coolant type), specify the spindle length LS as shown in the illustration. Air feed tube length LR is determined by LS. E.G. LR = LS + 17

In case of KPC43C048: LR = LS + 12
Chuck Adaptor and Retainer are options

Standard type jaw

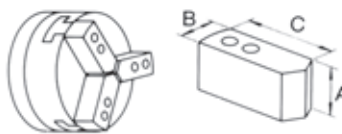

Pie type jaw



Standard type jaw Dimensions

Chuck	Jaw model	Mat-erial	Dimensions mm		
			A	B	C
KPC80 TYPE	KJ1A3-7	A l	19	20	38.4
	KJ1A3-15	A l	38	20	38.4
	KJ1A3-1	A l	25	20	38.4
	KJ1S3-7	S45C	19	20	38.4
	KJ1S3-15	S45C	38	20	38.4
KPC4 TYPE	KJ1A4-1	A l	25	20	48.4
	KJ1A4-7	A l	19	20	48.4
	KJ1A4-15	A l	38	20	48.4
	KJ1S4-1	S45C	25	20	48.4
	KJ1S4-2	S45C	51	20	48.4
	KJ1S4-7	S45C	19	20	48.4
	KJ1S4-15	S45C	38	20	48.4

Pie type jaw Dimensions

Chuck	Jaw model	Mat-erial	Dimensions mm	
			A	D
KPC80 TYPE	KJ3A3-1	A l	25	80
	KJ3S3-1	S45C	25	80
	KJ3S3-7	S45C	19	80
KPC4 TYPE	KJ3A4-1	A l	25	100
	KJ3A4-15	A l	38	100
	KJ3S4-2	S45C	51	100
	KJ3S4-7	S45C	19	100
	KJ3S4-15	S45C	38	100
KPC6 TYPE	KJ3A6-1	A l	25	150
	KJ3S6-1	S45C	25	150
	KJ3S6-7	S45C	19	150