

DIN-Type 3-Jaw Self-Centering Chucks VERTEX®

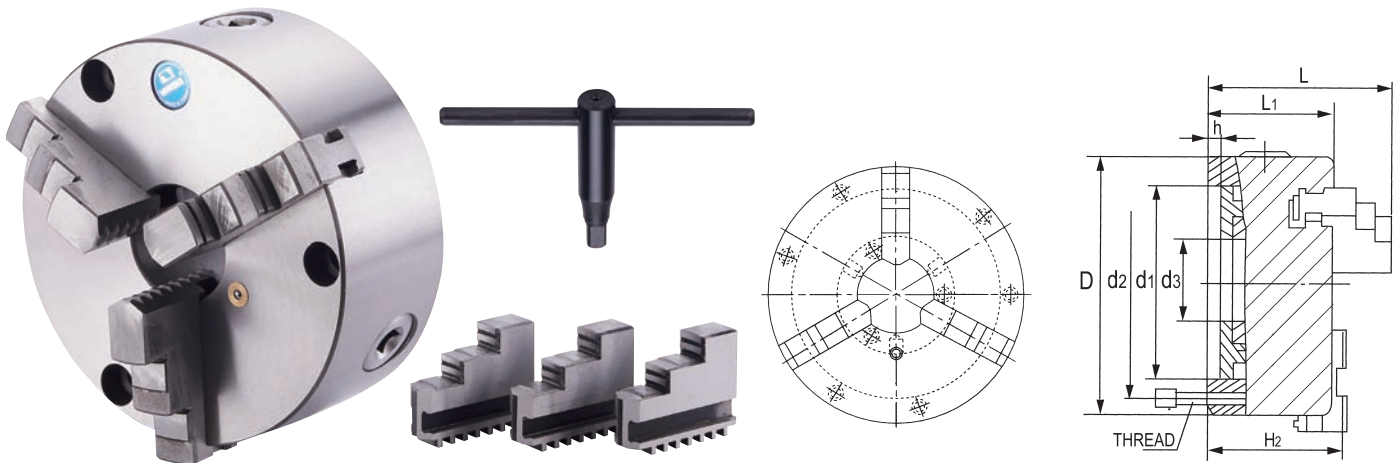

It have front mounting type as well.

SPECIFICATIONS

Unit:mm

ORDER NO.	D	d1	d2	d3	L	L1	h	THREAD	R.P.M. MAX SPEED	GRIPPING RANGE		WEIGHT (kgs)	CODE NO.
										O.D. RANGE	I.D. RANGE		
VSC-3D	80	56	67	16	66.5	50	4	3-M6	4000	Ø2-Ø70	Ø22-Ø63	1.9	5002-215
VSC-4D	100	70	83	22	74.5	55	3	3-M8	3500	Ø2-Ø90	Ø30-Ø80	3.3	5002-216
VSC-5D	125	95	108	30	84.5	58	4	3-M8	3000	Ø2.5-Ø125	Ø38-Ø110	5.2	5002-217
VSC-6D	160	125	140	45	94	65	5	6-M10	2500	Ø3-Ø160	Ø55-Ø145	9.1	5002-218
VSC-8D	200	160	176	65	109	75	5	6-M10	2500	Ø4-Ø200	Ø65-Ø200	16	5002-219
VSC-10D	250	200	224	80	120	80	5	6-M12	1600	Ø6-Ø250	Ø90-Ø250	27.5	5002-219A

4-Jaw Independent Chuck Plain Back

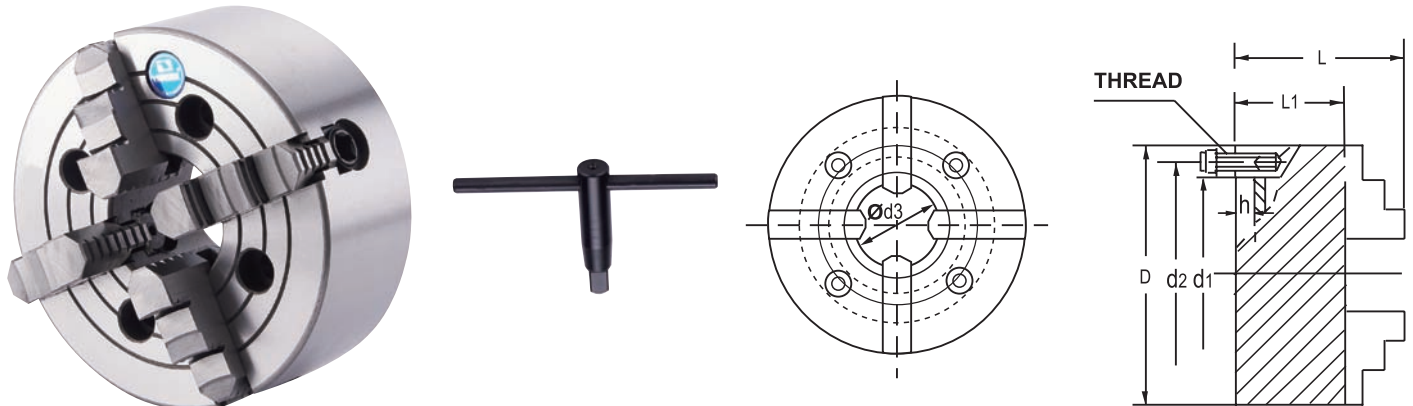

SPECIFICATIONS

Unit:mm

ORDER NO.	D-size	d1	d2	d3	L	L1	h	THREAD	R.P.M. MAX SPEED	GRIPPING RANGE		WEIGHT (kgs)	CODE NO.
										O.D. RANGE	I.D. RANGE		
VKC-4	100mm(4")	72	84	25	74	54	4.5	4-M8	2300	Ø6-Ø45	Ø40-Ø100	4	5002-220
VKC-5	125mm(5")	95	108	30	78	56			1900	Ø7-Ø57	Ø48-Ø125	5.1	5002-221
VKC-6	160mm(6")	65	95	45	93	65	5	4-M10	1500	Ø8-Ø80	Ø50-Ø160	8.3	5002-222
VKC-8	200mm(8")	75		56	107	75			1350	Ø10-Ø100	Ø63-Ø200	15.9	5002-223
VKC-10	250mm(10")	110	130	65	120	80	6	4-M12	1100	Ø15-Ø130	Ø80-Ø250	21.8	5002-224
VKC-12B	320mm(12")	140	165	95	134	90			850	Ø20-Ø176	Ø100-Ø315	43.8	5002-226
VKC-14	350mm(14")	130	168	125	143	95	8	4-M16	550	Ø20-Ø206	Ø100-Ø350	53.6	5002-227
VKC-16	400mm(16")	160	185						550	Ø25-Ø250	Ø118-Ø400	65	5002-228
VKC-20	500mm(21")	200	236	160	161	106	8	4-M20	350	Ø35-Ø300	Ø125-Ø500	105	5002-229
VKC-25	630mm(25")	220	258	180	175	118			10	280	Ø50-Ø400	Ø160-Ø630	175
VKC-32	800mm(32")	250	300	210	202	132	12	8-M20	200	Ø70-Ø540	Ø200-Ø800	300	5002-231
VKC-40	1000mm(40")	320	370	260	241	150	15	8-M20	150	Ø100-680	Ø250-1000	536	5002-232
VKC-50	1250mm(50")	400	500	305	256	165	15	8-M20	150	Ø170-900	Ø250-1250	905	5002-233