

# POWER TABLE FEED OPERATION MANUAL

AL-300S

AL-400S

AL-500S

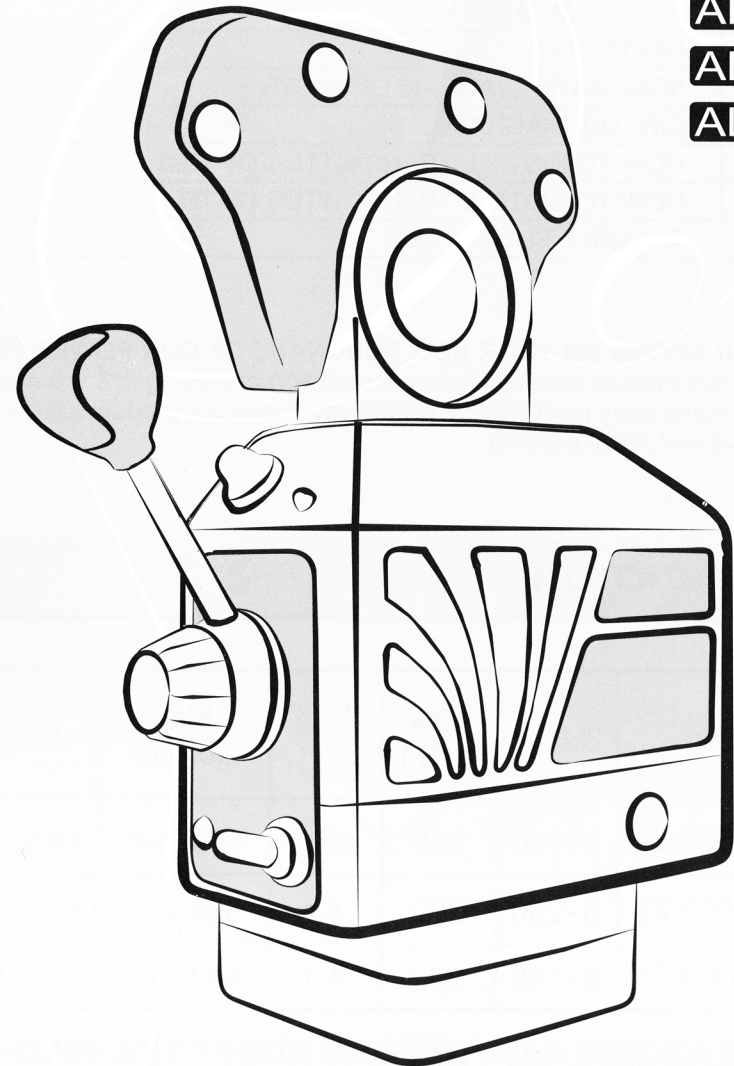

## PARTS LIST

NO.	PART NAME	PART NO.	SPECIFICATION	REMARK
78	RING OF POTENTIOMETER	E0929-02		
79	CAP OF POTENTIOMETER	E0929-03		
80	WASHER OF POTENTIOMETER	E0929-04		
81	NUT OF POTENTIOMETER	E0929-05		
82	400S/500S POTENTIOMETER	E0929V	10K $\Omega$	AL-500S/400S
	300S POTENTIOMETER	E0929P	500 $\Omega$	AL-300S
83	POWER CORD	E0930	0.75x 3Cx 2.7M	
84	CRESCENT RING	E0934-01	S38	
85	WASHER	E0934-02	1.5x $\phi$ 38x $\phi$ 54	
86	SPRING WASHER	E0934-03	6205	
87	HUB OF ZYTEL GEAR	E0934-04		
88	CRESCENT RING	F01001	IR24	
89	E-RING	F10040	E4	
90	E-RING	F10050	E5	
91	MICRO SWITCH	F1104		
92	CONTROL CORD	F1106A-2	0.75x 4Cx 1.7M	AL-500S/400S
	CONTROL CORD	F1106V	0.75x 4Cx 1.7M	AL-300S
93	TRAVEL STOP	G0100-011		
94	NUT	G0103		
95	CRESCENT RING	G0106		
96	SPRING	G0107		
97	TRAVEL STOP SHAFT	G0108		
98	NUT	N10020	M 2	
99	NUT	N10030	M 3	
100	NUT	N22001	5/16"	
101	CARBON BRUSH CAP	E0906		
102	PLASTIC GEAR	P01007		
103	BEVEL GEAR	P01012	16x 4	FOR AL SER.
	BEVEL GEAR	P01013	5/8"x 1/8"	FOR AL SER.
	BEVEL GEAR	P01014	22x 4	FOR AL SER.
	BEVEL GEAR	P01016	16x 4	FOR SP SER.
	BEVEL GEAR	P01025	5/8"x 3	
	BEVEL GEAR	P01026	17x 5	
	BEVEL GEAR	P01039	20x 6	
	500S BEVEL GEAR	P01017	5/8"x 1/8"	FOR SP SER.

## PARTS LIST

NO.	PART NAME	PART NO.	SPECIFICATION	REMARK
50	CAPACITOR	C0506		
51	MICRO SWITCH HOLDER	C0507		
52	MICRO SWITCH ASSEMBLY	C0508		
53	MOUNTING PLATE	C0508-01		
54	MICRO SWITCH	C0508-02		
55	BOTTOM COVER	P01809		AL-500S
56	BOTTOM HOUSING	P01806		
57	250 CAM ASSEMBLY	E0902V		
	235 CAM ASSEMBLY	E0902P		
58	CARBON BRUSH HOLDER	P01004		
59	BRUSH	E0905		
60	ON-OFF SWITCH	E0907		
61	CAP OF ON-OFF SWITCH	E0907-01		
62	WASHER	E0907-02		
63	SPRING WASHER	E0910	627	
64	SET SCREW	E0911	1/4"x 1/4"	
65	SPEED CONTROL KNOB	P01928		
66	HANDLE KNOB	P01927		
67	180° CONTROL HANDLE	P01810		
	90° CONTROL HANDLE	P01811		
68	INNER RING	E0913A		
69	CIRCUIT BOARD INSULATOR	E0915V		
70	400S/500S CIRCUIT BOARD ASSEMBLY	E0916V		AL-500S/400S
	300S CIRCUIT BOARD ASSEMBLY	JC2H		AL-300S
	CE CIRCUIT BOARD ASSEMBLY	JC5H		CE-300S
71	STRAIN RELIEF	E0917		
72	LIFT FORK SHAFT	E0922		
73	AL ARMATURE ASSEMBLY	E0925V		AL-400S/300S
	SP ARMATURE ASSEMBLY	P01907		AL-500S
74	400S/500S MOTOR FIELD	E0926V		AL-400S/500S
	300S MOTOR FIELD	E0926P		AL-300S
75	BEARING MOUNT	E0927A		
76	BUSHING	E0928	$\phi$ 8x $\phi$ 14.8x 20	
77	STRAIN OF POTENTIOMETER	E0929-01		

## PARTS LIST

NO.	PART NAME	PART NO.	SPECIFICATION	REMARK
17	BUSHING BEARING	A0103	φ6xφ12x 11.5mm	
18	DRIVE GEAR SHAFT	A0106		AL-400S/300S
	DRIVE GEAR SHAFT	P01022		AL-500S
19	DRIVE GEAR	A0106V		AL-400S/300S
	DRIVE GEAR	P01021		AL-500S
20	SPACER	A0109		
21	LIGHT TRANSMITTER	A0110		
22	HEX. SEAL BOOT	A0111-01		
23	NUT FOR RAPID SWITCH	A0111-01A		
24	RAPID SWITCH PLUNGER	A0111-02		
25	SPRING FOR RAPID SWITCH	A0111-03		
26	RAPID SWITCH HOUSING	A0111-04		
27	RAPID SWITCH ASSY	A0111-1-5		
28	SPRING FOR TOP HOUSING	A0112		
29	ADAPTOR	P01808		
30	SPRING FOR CLUTCH	A0301-05		
31	WASHER TRA	A0301-06	512	
32	WASHER BEARING NTA	A0301-07	512	
33	BEARING CUP	A0301-8		
34	LIFTFORK	A03011-9		
35	WASHER	A0301-10	1×φ8×φ18mm	
36	SHAFT MOUNT	A0301-12A		
37	WIRE	ALW-25-1	24AWGx L59mm	
38	WIRE	ALW-26	18AWGx L50mm	
39	WIRE	ALW-3	22AWG	
40	WIRE	ALW-6	22AWGx L116mm	
41	WIRE	ALW-7	22AWGx L160mm	
42	WIRE	ALW-8	22AWGx L100mm	
43	WIRE	ALW-9	22AWGx L100mm	
44	BEARING	B00001	627ZZ	
45	BEARING	B00006	608ZZ	
46	MICRO SWITCH HOLDER	C0501		
47	MICRO SWITCH ASSEMBLY	C0501-6V		
48	SWITCH ACTURATOR	C0502		
49	MICRO SWITCH	C0504		

## PARTS LIST

NO.	PART NAME	PART NO.	SPECIFICATION	REMARK
	500S BEVEL GEAR	P01032	22x 4	
	500S BEVEL GEAR	P01054	20x 6	
104	LIMIT SWITCH COVER	P01015		
105	LIMIT SWITCH HOLDER	P01018		
106	ACTUATOR	P01019		
107	LIFTFORK RING	P01028		
108	HOLD PLATE	P01040	30°	
109	DRIVE GEAR ASSEMBLY	P01901		
110	LIFTFORK ASSEMBLY	P01903		
111	MICRO SWITCH ASSEMBLY	P01904		
112	250/500S POTENTIOMETER ASSEMBLY	P01905		
	235/99 POTENTIOMETER ASSEMBLY	P01908		
113	ZYTEL GEAR ASSEMBLY	P01909		
114	LIMIT SWITCH ASSEMBLY	P01910		AL-400S/500S
	LIMIT SWITCH ASSEMBLY	P01924		AL-300S
	LIMIT SWITCH ASSEMBLY	P01925		CE-400S/500S
	LIMIT SWITCH ASSEMBLY	P01926		CE-300S
115	TRAVEL STOP SET	P01916		
116	BEVEL GEAR SET	P01917	5/8"	AL-400S/300S
117	LIFTFORK ASSEMBLY	P01923		
118	SCREW	T12010	2x 10 mm	
119	SCREW	T13015	3x 15 mm	
120	SCREW	T13020	3x 20 mm	
121	SCREW	T13030	3x 30 mm	
122	SCREW	T14006	4x 6 mm	
123	SCREW	T14010	4x 10 mm	
124	SCREW	T15010-1	4x 10 mm	
125	SCREW	T14070	4x 70 mm	
126	SET SCREW	T20001	3/16"x 3/8"	
127	SET SCREW	T20003	5/16"x 1"	
128	SET SCREW	T55035	5x 35 mm	
129	SET SCREW	T60001	1/4"x1"	
130	SET SCREW	T74004	4x 4 mm	
131	PIN	U33025	φ2x 24.8 mm	
132	PIN	U35016	φ2.5x 16 mm	

## PARTS LIST

NO.	PART NAME	PART NO.	SPECIFICATION	REMARK
133	PIN	U33015	φ3x 15 mm	
134	PIN	U35014	φ5x 14 mm	
135	PIN	U42515	φ2.5x 15 mm	
136	SPRING	U43014	φ3x 13.7 mm	
137	WASHER	U43017	φ3x 17.5 mm	
138	WASHER	W04001		
139	WASHER	W10050	1x φ5x φ12 mm	
140	WASHER	W10080	1x φ8x φ18 mm	
141	WASHER	W10080-1	0.6x φ8x φ12 mm	
142	SPRING WASHER	W20040	φ4 mm	
143	ON-OFF BRAND	D20283		
144	LIMIT SWITCH FIXTURE	P01919		
145	EXTENSION SHAFT	P01922	16 t	OPTION
	EXTENSION SHAFT	P01929	20 t	OPTION
146	T-WAY TRACK	A0301-15A	60 CM	OPTION
	T-WAY TRACK	A0301-15B	66 CM	OPTION
	T-WAY TRACK	A0301-15E	30 CM	OPTION
147	ALUM STAND	PFB-01	28 t	OPTION
	ALUM STAND	PFB-02	35 t	OPTION
	STAND	PFB-18	13 t	OPTION
148	EXTENSION SHAFT	PFB-06	L 54.7 mm	OPTION
	EXTENSION SHAFT	PFB-07	L 69 mm	OPTION
	EXTENSION SHAFT	PFB-07A	L 79 mm	OPTION
	EXTENSION SHAFT	PFB-08	L 80 mm	OPTION
	EXTENSION SHAFT	PFB-15	L 52 mm	OPTION
	EXTENSION SHAFT	PFB-16	L 60 mm	OPTION
149	EXTENSION SHAFT RING	PFB-03	L 40 mm	OPTION
	EXTENSION SHAFT RING	PFB-04	L 54.7 mm	OPTION
	EXTENSION SHAFT RING	PFB-05	L 65 mm	OPTION
	EXTENSION SHAFT RING	PFB-09	L 27 mm	OPTION
	EXTENSION SHAFT RING	PFB-10	L 33 mm	OPTION
	EXTENSION SHAFT RING	PFB-13	L 30 mm	OPTION
	EXTENSION SHAFT RING	PFB-14	L 42 mm	OPTION
150	NUT	PFR-76	1/2-20x14.3mm	
151	WASHER	P01823	3x φ16x φ25.4mm	

## ASSY-LIMIT ASSEMBLY

### CAUTION

- It will damage the gear of power feed if you suddenly change the direction of power feed by pushing the direction control handle while the machine is under high-speed operation. If you intend to change the direction, please push the handle to the "off" position. Waiting until the machine is completely stopped, then push the handle to your intended direction.
- Please make sure the position of the stop screw for your milling machine is keeping on "loose" status.
- While the power feed is under operation, please don't change to use manual control the direction suddenly.
- POWER FEED can only move to one direction.  
CHECK: If ASSY-LIMIT SWITCH is normal.
- Touch ASS-LIMIT SWITCH POWER FEED in-between the TABLE and unable to stop it.  
CHECK: If ASS-LIMIT SWITCH is normal.

### PARTS LIST

NO.	PART NAME	PART NO.	SPECIFICATION	REMARK
1	TOP HOUSING	P01807		AL-500S
	TOP HOUSING	P01824		AL-400S/300S
2	BEVEL GEAR NUT	A0100-01	0.2x φ34x φ45mm	
3	WASHER	A0100-02A	0.4x φ34x φ45mm	
4	WASHER	A0100-02B	0.6x φ34x φ45mm	
5	WASHER	A0100-02C	0.1x φ34x φ45mm	
6	WASHER	A0100-02D	0.2x φ16x φ23.5mm	
7	WASHER	A0100-04A	0.4x φ16x φ23.5mm	
8	WASHER	A0100-04B	0.6x φ6x φ23.5mm	
9	WASHER	A0100-04C	0.1x φ16x φ23.5mm	
10	WASHER	A0100-04E	2x φ16x φ25.4mm	
11	WASHER	A0100-07A		
12	NEEDLE BEARING	A0101A		
13	INNER RING	A0101B		
14	NEEDLE BEARING	A0101C		
15	CIRCUIT BREAKER	A0102		
16	CAP OF CIRCUIT BREAKER	A0102-01		

## HOW TO INSTALL KNEE LIFT FEED(D TYPE)

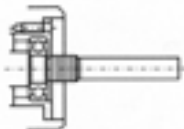
- 

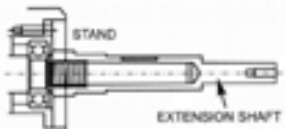
**Note:** Remove hand crank, dial, dial socket, Bearing flange and.....Etc.
  - 

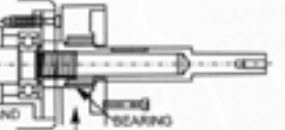
**Note:** Install extension shaft.  
**Important:**  
1. Shaft end must be against inner ring of bearing.  
2. Inner shaft is 16 or 18 threaded unc.
  - 

**Note:** Tighten stand to flange then tighten knee feed on the flange.  
**Important:** For angular positioning.
  - 

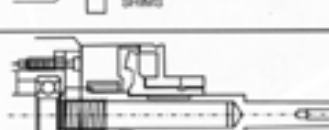
**Note:** Install gear key not in.  
**Important:** Use hand to push & turn bevel gear to check backlash.  
1. If necessary add a few shims to obtain proper backlash.  
2. Modify leading edge of gear to obtain proper backlash. Then repack gear with grease. Replace gear then push and turn to check for backlash.
  - 

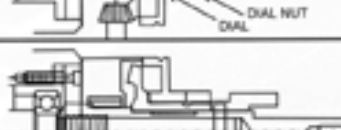
**Note:** Remove the bevel gear after STEP 4 is O.K. then install key, replace gear, install dial, and tighten dial nut. Add a few shim if dial is grinding the gear.  
**Important:** Pack with grease before installing the gear. Do not use silicon-type grease.
  - 

**Note:** Install checkclutch against bevel gear then drive through one hole of 5mm Dia. Then drive spring pin.  
**Important:** Be sure you have followed each step carefully and correctly before installing the spring pins.  
**Suggestions:** Install hand crank rotate in clockwise direction to check for proper shimming and that there is no binding action.
  - 

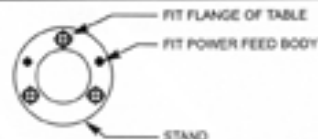
**Note:** Install spring handcrank (already installed), then tighten washer and screw.  
**Important:** For operational safety, please lubricate this part and install as per instructions.
- 

## CIRCUIT DIAGRAM AL-300S

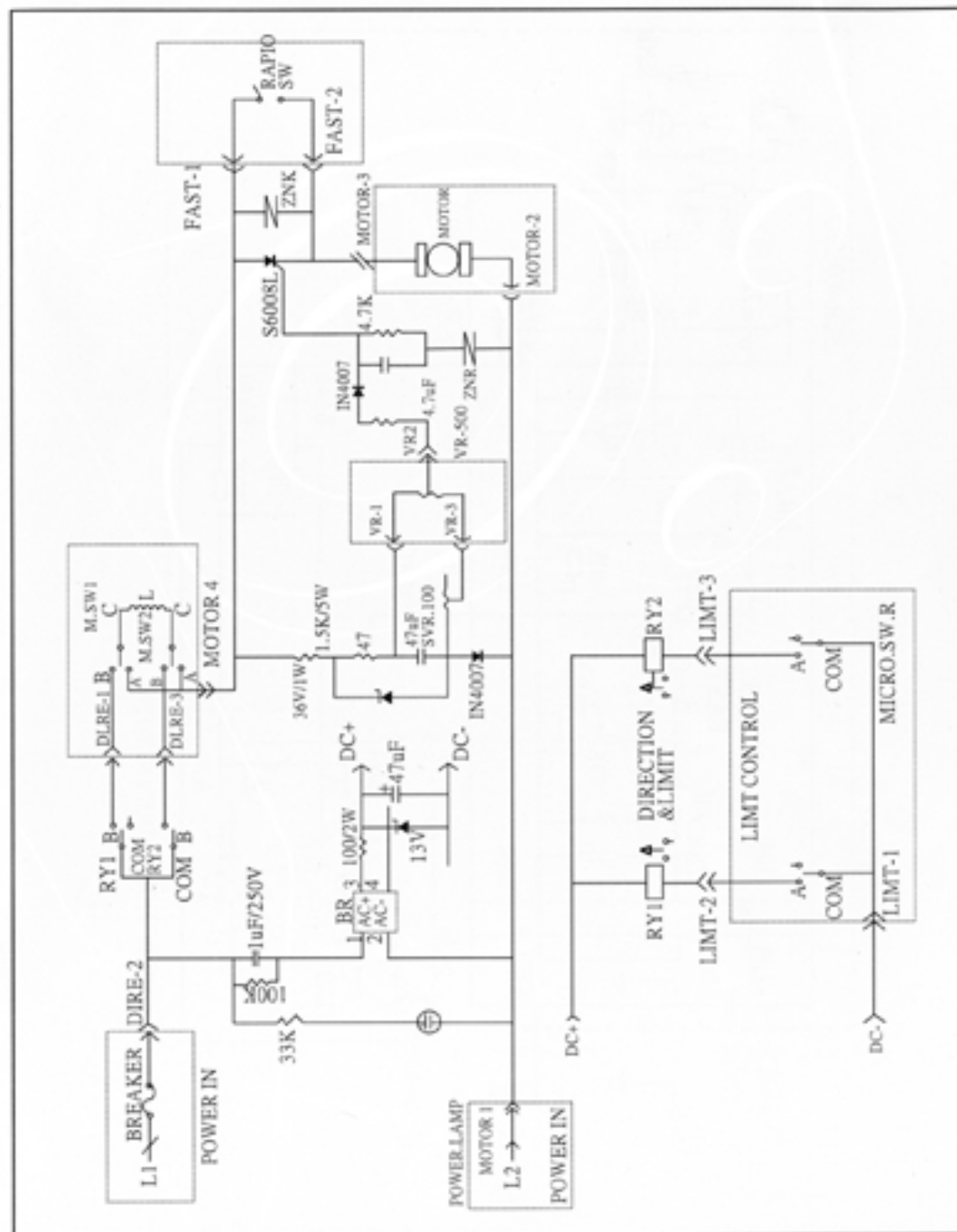

## CIRCUIT DIAGRAM AL-500S/AL-400S

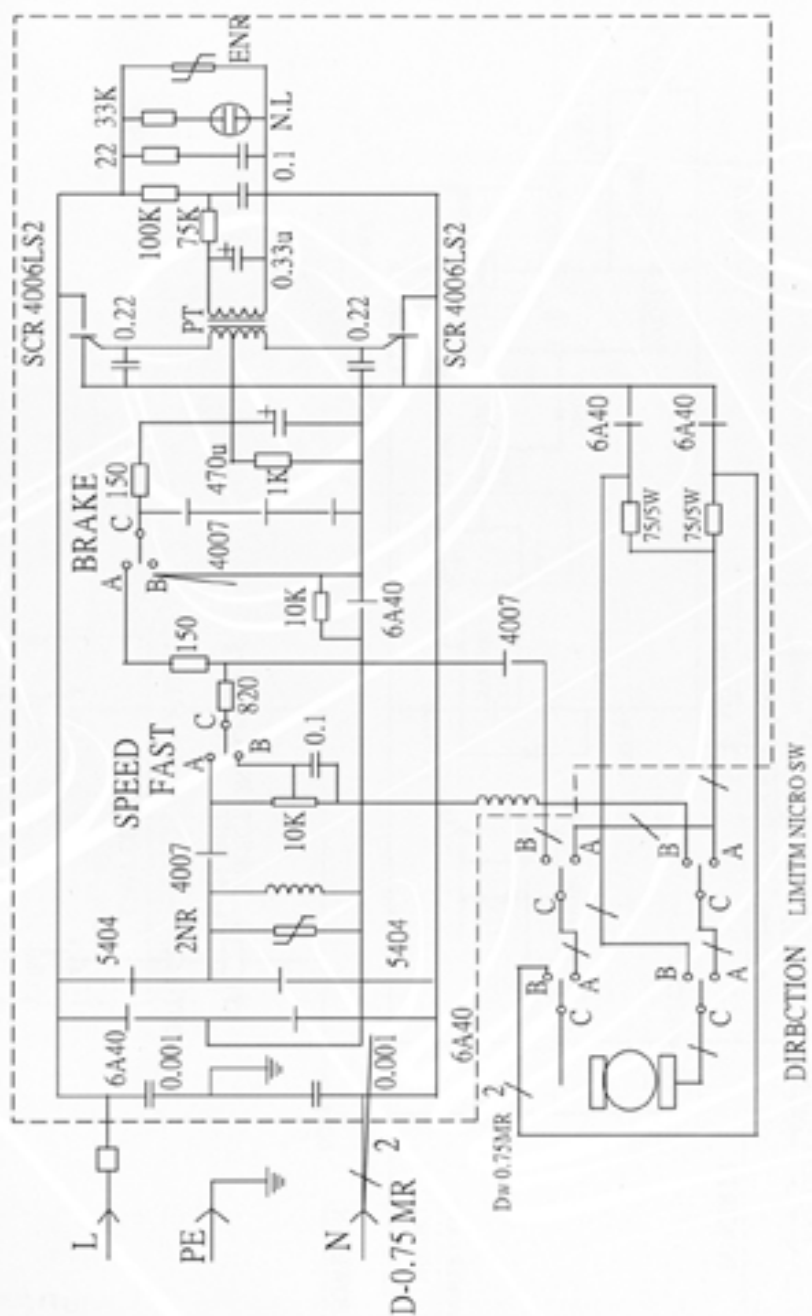

## HOW TO INSTALL CROSS FEED(B TYPE)

### HOW TO INSTALL T-WAY TRACK FOR CROSS-FEED

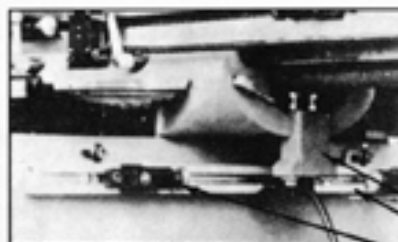

T-way bar and bracket for limit switch are designed for simple installation on cross slide.

FIXED SUPPORT  
T-WAY TRACK  
STOP BLOCK

### INSTALLATION INSTRUCTIONS

For ideal installation, you should not modify the cross travel lead screw.

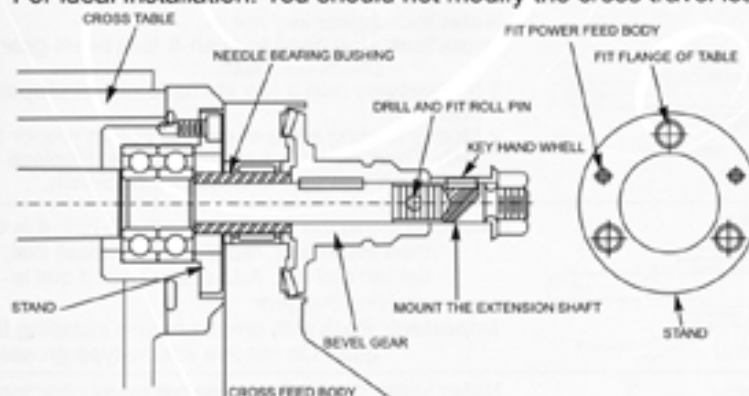

### HOW TO INSTALL T-WAY TRACK FOR KNEE-LIFT FEED

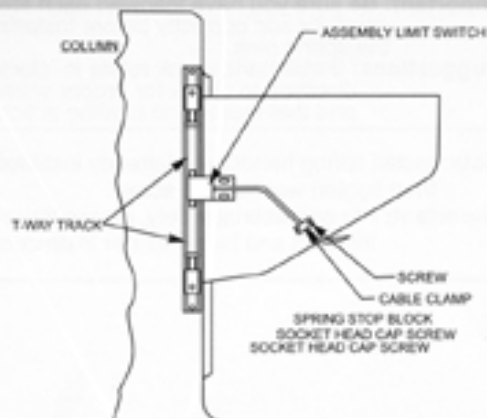

VIEW OF LEFT SIDE OF  
KNEE AND COLUMN

## HOW TO INSTALL THE LONGITUDINAL FEED(A TYPE)

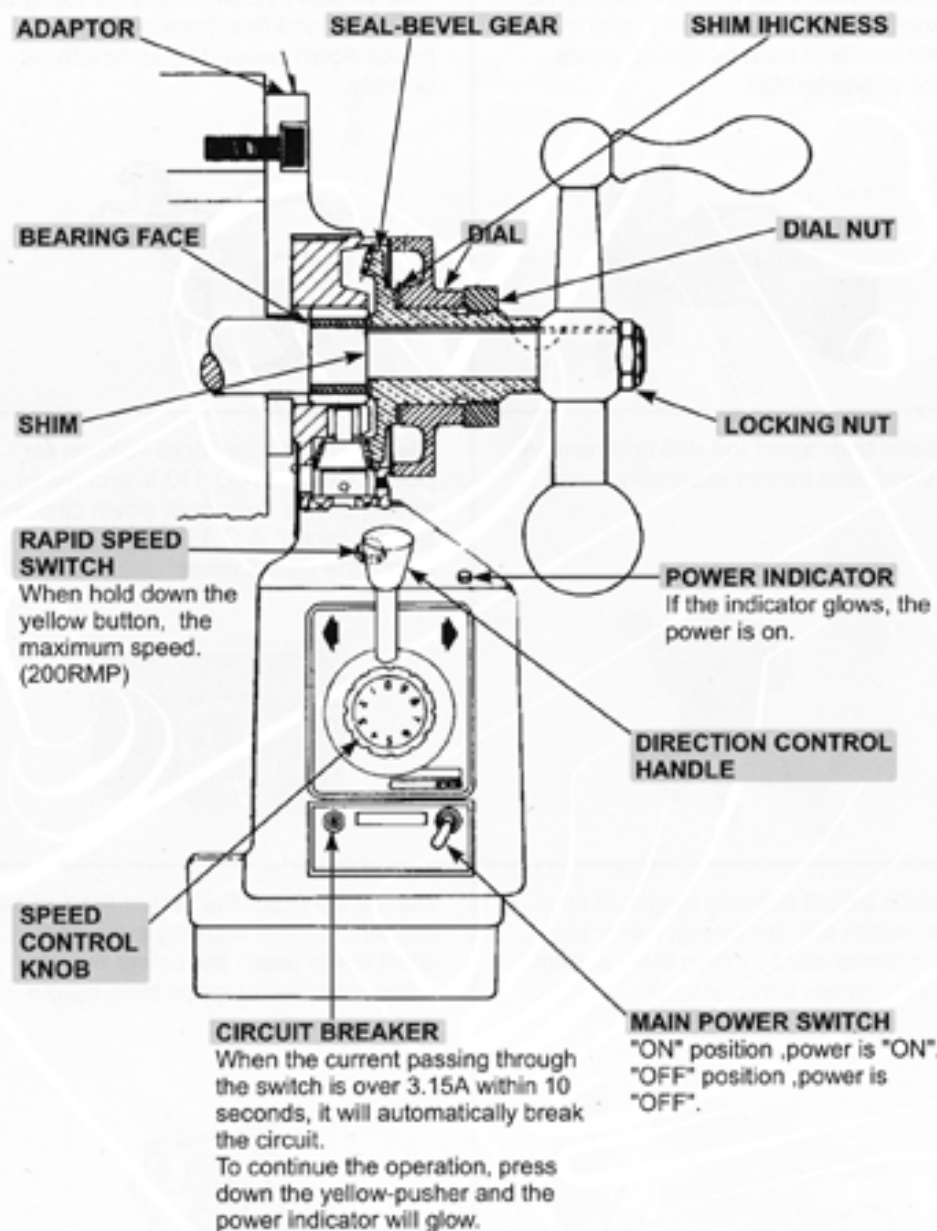

## HOW TO INSTALL TRANSMITTER OF TR-1(ONE OUTPUT)

TRANSMITTER OF TR-1 IS USED FOR 220V, 240V, 380V AND 415V THEN TRANSFER TO 110V. ATTACHING POWER PILOT LAMP AND ONE OUTPUT OUTLET.

### ASSEMBLING GUIDE:

1. Make sure the voltage of working environment.
2. Choose the exact input point and well fix up.
3. Make sure whole screws of transformer are well locked.
4. Setting transformer on stable and dry wall.
5. Collecting cable and wire on the wire box of working place.
6. Keep from accident caused, don't disassemble and refit locked parts or wiring of transformer when assembly proceeding.

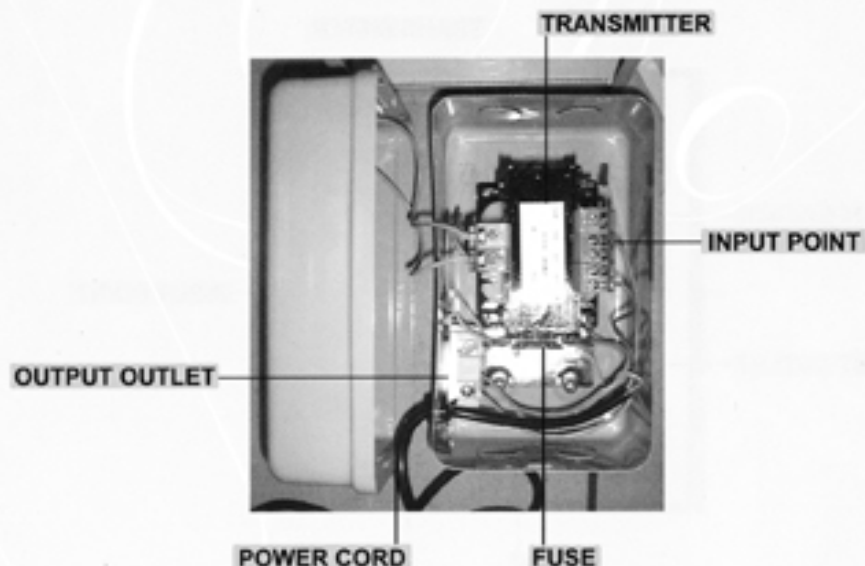

### CIRCUIT

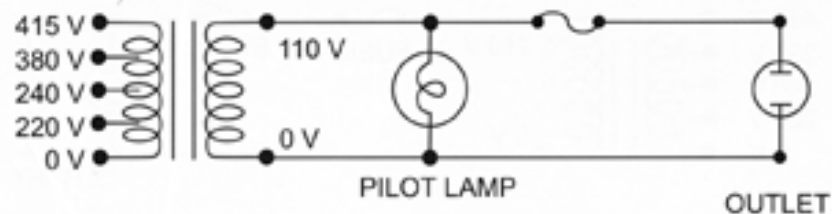

## HOW TO INSTALL TRANSMITTER OF TR-2(TWO OUTPUT)

TRANSMITTER OF TR-2 IS USED FOR 220V, 240V, 380V AND 415V THEN TRANSFER TO 110V . ATTACHING POWER SWITCH AND TWO OUTPUT OUTLET.

### ASSEMBLING GUIDE:

1. Make sure the voltage of working environment.
2. Choose the exact input point and well fix up.
3. Make sure whole screws of transformer are well locked.
4. Setting transformer on stable and dry wall.
5. Collecting cable and wire on the wire box of working place.
6. Keep from accident caused, don't disassemble and refit locked parts or wiring of transformer when assembly proceeding.

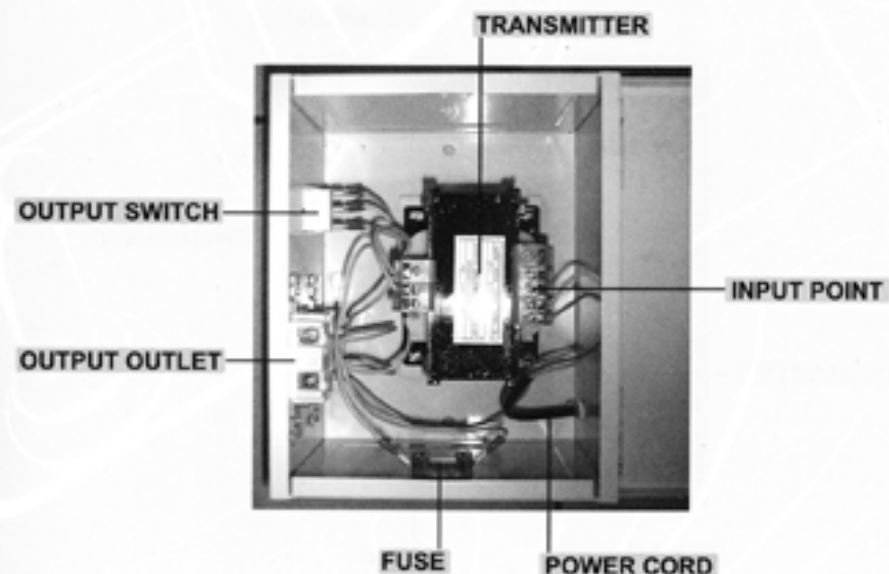

### CIRCUIT

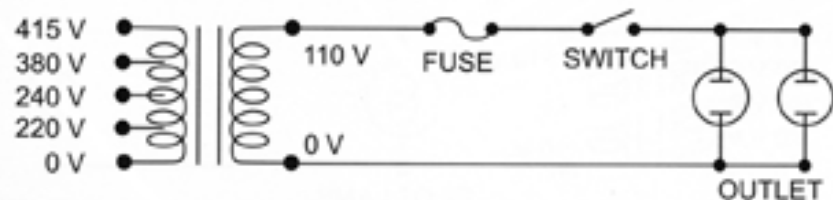

## WARNING

Please make sure if power supply be turned off before assembly, and avoid from accident caused during procedure of assembly.

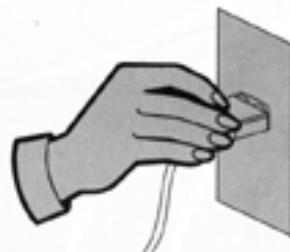

Please don't disassemble for fixing or refitment and free from accident or break down caused by unhealth assembly.



Please take apart the drill and remove worked item before assembly.



Please make sure input voltage for power feed as A.C. 110 V and avoid wrong power then burn down circuit board, except A.C. 110 V, please adopt the transformer.



Please adjust suitable length of cord and watch out the wiring, never pressure power cord by clog then ambroin broken cause short or spark.



Please don't set the power feed in excessive wet working zone and don't wash down the power feed by water or water shipped then cause short or spark.



## CONTENT

PAGE	INDEX
1	SPECIFICATION
2	WARNING
3	HOW TO INSTALL THE LONGITUDINAL FEED
4	HOW TO INSTALL CROSS FEED
5	HOW TO INSTALL KNEE LIFT FEED
6	ASSY-LIMIT ASSEMBLY
7,8,11~13	PARTS LIST
9,10	SCHEMATIC DIAGRAM OF PARTS
14,15	CIRCUIT DIAGRAM
16	HOW TO INSTALL TRANSMITTER OF TR-1
17	HOW TO INSTALL TRANSMITTER OF TR-2
18	TROUBLE SHOOTING

### CONGRATULATIONS ON YOUR NEW PURCHASE OF OUR POWER FEED

Please read this manual carefully before installation and using it. It will also help you to solve some easy problems by yourselves. Hope our product will bring you more effective and joyful working.

## SPECIFICATION

Model	R.P.M.	Max R.P.M.	Bevel Drive Gear Rate	Max Torque	Voltage
AL-500S(X,Y,Z)	4~160	160	4:8:1	650 in-lb	110V 60Hz
AL-400S(X,Y,Z)	0~200	200	4:1	550 in-lb	110V 60Hz
AL-300S(X,Y,Z)	0~140	200	4:1	440 in-lb	110V 60Hz

**VOLTAGE AS 220V-440V HAVE TO ADOPT TRANSFORMER**

## TROUBLE SHOOTING

### THE POWER FEED DOES NOT WORK AND THE POWER INDICATOR DOES NOT GLOW :

- 1.Ensure there is no problem with power supply.
- 2.Check if the circuit breaker on the power feed unit kicked out.
- 3.Check for proper contact at the ON-OFF switch.

### THE MOTOR DOES NOT WORK WHEN PUSH DIRECTION LEVER TO EITHER LEFT OR RIGHT :

- 1.Open power feed unit by loosening bottom 4 hex screws.
- 2.Check if the carbon brush is making proper contact with the armature or if carbon brush is all used up already.
- 3.Check that internal wiring to the printed circuit board are all connected.
- 4.Check that the potentiometer connections are intact and that it is functioning properly.

### SPEED CONTROL ERRATIC OR ALWAYS AT HIGH SPEED ONLY :

- 1.Check rapid micro switch. Make sure it is not stuck. If its position is too high up, lightly tap on it to lower.
- 2.Check V.R. is in good connection and proper function.

### BREAKER ALWAYS KICKS OUT ON POWER FEED UNIT UNDER NORMAL USAGE :

Short circuit in the armature, need to be replaced new armature.

### CURRENT LEAKAGE :

- 1.Check limits switch assembly for possible short.
- 2.Check armature by first removing the brush cap.
- 3.Measure for short with an ohmmeter across the carbon brush and the outer cover of the power feed unit.

# SCHEMATIC DIAGRAM OF PARTS

# SCHEMATIC DIAGRAM OF PARTS

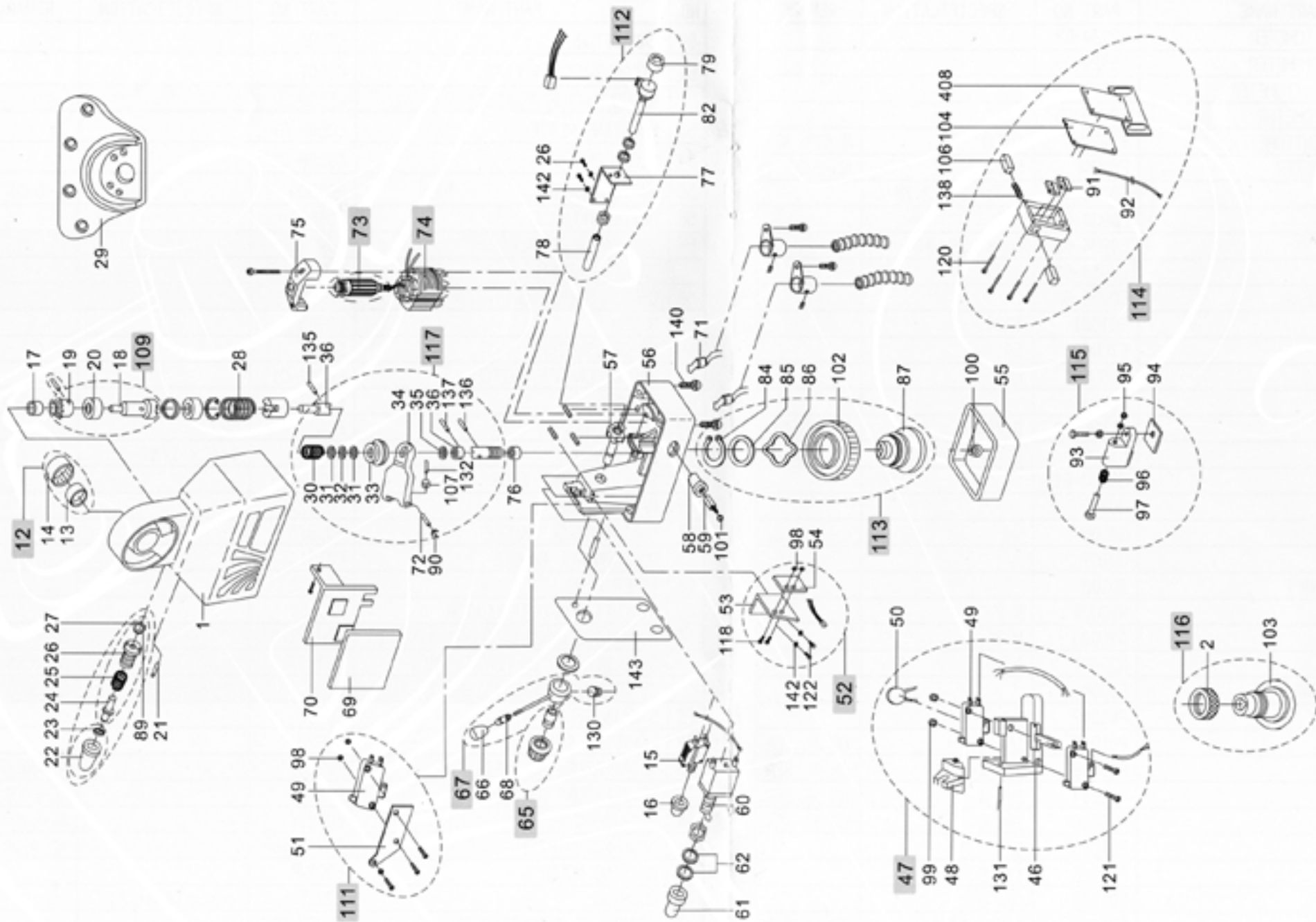

3-10	148	147	150
11	149	146	151